



ISBN: 978-81-951982-9-0

Advanced Research in Material and Chemical Science

Volume I

Editor

Dr. Nana Shejwal

Dr. Simanchal Das

Dr. Pralhad V. Rege

Dr. Venkatesh Gopula

Published By: Bhumi Publishing

First Edition: 2021

Advanced Research in Material and Chemical Science

Volume I

(ISBN: 978-81-951982-9-0)

Editors

Dr. Nana N. Shejwal

All India Shri Shivaji Memorial Society,

College of Engineering,

Pune – 411 001, M.S., India

Dr. Simanchal Das

Roland Institute of Technology,

Berhampur, 761 008,

Odisha, India

Dr. Pralhad V. Rege

St. Xavier's College,

5 - Mapahapalika Marg,

Mumbai – 400 001, M.S., India

Dr. Venkatesh B. Gopula

Anandibai Raorane Arts, Commerce and

Science College, Vaibhavwadi

Dist – Sindhudurg 416 810, M.S., India



Bhumi Publishing

2021

First Edition: 2021

ISBN: 978-81-951982-9-0



© Copyright reserved by the publishers

Publication, Distribution and Promotion Rights reserved by Bhumi Publishing, Nigave Khalasa, Kolhapur
Despite every effort, there may still be chances for some errors and omissions to have crept in
inadvertently.

No part of this publication may be reproduced in any form or by any means, electronically, mechanically,
by photocopying, recording or otherwise, without the prior permission of the publishers.

The views and results expressed in various articles are those of the authors and not of editors or
publisher of the book.

Published by:

Bhumi Publishing,

Nigave Khalasa, Kolhapur 416207, Maharashtra, India

Website: www.bhumipublishing.com

E-mail: bhumipublishing@gmail.com

Book Available online at:

<https://www.bhumipublishing.com/books/>



PREFACE

We are delighted to publish our book entitled "Advanced Research in Material and Chemical Science Volume I". This book is the compilation of esteemed articles of acknowledged experts in the fields of Chemical Science, Material Science and Nanotechnology.

This book is published in the hopes of sharing the excitement found in the research and study of chemical and material science. Chemical and material science can help us unlock the mysteries of our universe, but beyond that, conquering it can be personally satisfying. We developed this digital book with the goal of helping people achieve that feeling of accomplishment.

The articles in the book have been contributed by eminent scientists, academicians. Our special thanks and appreciation goes to experts and research workers whose contributions have enriched this book. We thank our publisher Bhumi Publishing, India for taking pains in bringing out the book.

Finally, we will always remain a debtor to all our well-wishers for their blessings, without which this book would not have come into existence.

- Editorial Team

Advanced Research in Material and Chemical Science Volume I

ISBN: 978-81-951982-9-0

CONTENTS

SR. NO.	CHAPTER AND AUTHOR(S)	PAGE NO.
METHODS USING ADSORPTION AND SEPARATION		
1	OF GASES ON SOLIDS/LIQUIDS M. P. SINGH AND P.K. SINGH	1 – 8
CYCLODEXTRIN AND ITS APPLICATION		
2	IN CHEMISTRY SIMANCHAL DASH	9 – 20
SIMULATION AND EVALUATION OF LI-FI DATA		
TRANSMISSION AND RECEPTION USING		
3	LED AND PHOTODIODE B. GOPINATH, V. K. AMALA, R. AISHWARYA AND N. DINESHKUMAR	21 – 26
COMPARATIVE STUDY OF TEACHING METHODS		
4	IN THE SUBJECT OF CHEMISTRY OMPRAKASH S. CHAVAN	27 – 40
NANOTECHNOLOGY FOR		
5	WASTEWATER TREATMENT LEKSHMI R BABU AND VIDYA KV	41 – 45
BIOFUEL FOR ENVIRONMENTAL SUSTAINABILITY		
6	IN INDIA - AN OVERVIEW KAMALA MITRA	46 – 51
USE OF WASTE EGGSHELL MEMBRANE IN		
7	PREPARATION OF LITHIUM-ION BATTERIES SONIA DESWAL AND NARAYAN D. TOTEWAD	52 – 60
RECENT APPLICATIONS AND DEVELOPMENTS		
8	OF NANOTECHNOLOGY IN NANOMEDICINE SHALMALI HUI	61 – 73

9	ORGANOCATALYSIS: AN IMPORTANT STRATEGIC TOOL FOR TOTAL SYNTHESSES VENKATESH B. GOPULA	74 – 82
10	STUDY OF LORENTZ TRANSFORMATION EQUATIONS FOR SPACE AND TIME SANJAY SINGH	83 – 87
11	A SHORT REVIEW ON IONIC LIQUIDS STABILIZED COPPER AND COPPER OXIDE NANOPARTICLES AS CATALYSTS FOR ORGANIC CHEMICAL REACTIONS RAJARAJESWARI A AND STELLA S	88 – 98
12	IMPORTANCE AND APPLICATIONS OF NANOPARTICLES IN DAILY LIFE JYOTI AGASHE	99 – 105

METHODS USING ADSORPTION AND SEPARATION OF GASES ON SOLIDS/LIQUIDS

M. P. Singh¹ and P. K. Singh²

¹Department of Chemistry

²Department of Physics

Shri Sadguru Saibaba Science and Commerce College,

Ashti, Maharashtra - 442707 (India)

Corresponding author E-mail: 1drmpptomar@gmail.com, 2singhpk77@gmail.com

Abstract:

In this chapter, most of the attention is given to Adsorption and Separation of gases by using the Gibbs adsorption equation for composition of two-component phase and change in chemical potential due to mole fraction for taking solid–gas and liquid–gas interfaces. And using surface separation and relative adsorption at constant temperature, solute concentration like solute atoms of large positive size or large positive mixing enthalpies, partial pressure, energy versus composition at infinite dilution, describing the effect of an impurity on the surface energy, using electronegative element on metallic surfaces and refer Henry's law. And studying adsorption isotherm with frequently observing consistent patterns in enthalpies of adsorption.

Keywords: Gibb's adsorption equation, enthalpy of adsorption, relative adsorption, adsorption isotherm, partial pressure,

Introduction:

Physical and chemical adsorption of gases on solids are the two types of adsorption. Physical adsorption is characterised by a low enthalpy of adsorption and reversible adsorption. Adsorption isotherms are often used to explain the adsorption properties of these situations. Chemical adsorption/desorption or separation, on the other hand, has far higher enthalpies and is usually irreversible at low temperatures. Because of the presence of solid ionic or covalent bonds, it is often followed by surface reconstruction.

The Gibbs adsorption equation

Below is a systematic description of the adsorption of an adsorbent of a solution β on an adsorbate α . The adsorbent is made up of atoms or molecules, and the solution is either a liquid or a gas, with the adsorbate being either a solid or a liquid phase. Both solution β and process α are multi-component structures in general. The adsorbent concentration at the interface between the two phases is represented [1-4] by the adsorption (Γ) which is determined by eq.-1.

$$\Gamma_i = \frac{n_i^\sigma}{A_s} \dots\dots 1$$

Γ_i may become positive or negative, depending on the particular interface in process.

The system's internal energy is seen in Fig.-1

$$U = TS - p^\alpha V^\alpha - p^\beta V^\beta + \sum_{i=1}^C n_i \mu_i + \sigma A_s \dots 2$$

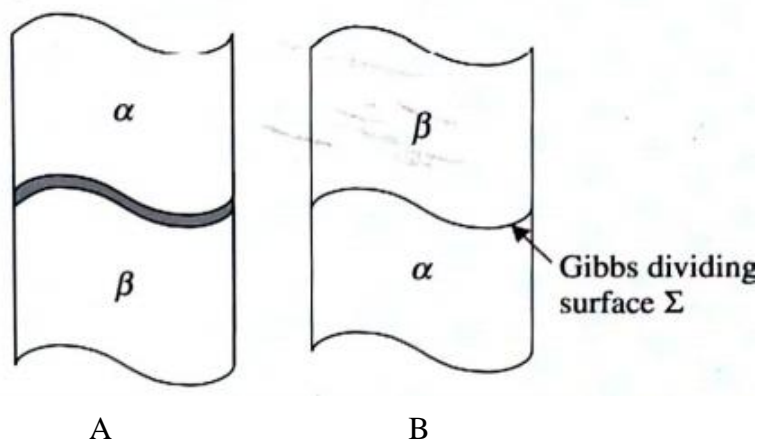

Figure 1: (A) A genuine physical interface between two homogeneous phases α and β is depicted. (B) A fictitious Gibbs separating surface Σ .

The internal energy of the dividing surface is obtained by subtracting the internal energy of the two homogeneous phases adjacent to the dividing surface from eq.-2

$$U^\sigma = TS^\sigma + \sum_{i=1}^C n_i^\sigma \mu_i + \sigma A_s \dots 3$$

Eq.-3 is differentiated and compared with eq-4, we get the Gibbs–Duhem eq.-5 in internal energy for a device with a non-zero surface energy:

$$dU^\sigma = TdS^\sigma + \sum_i \mu_i dn_i^\sigma + \sigma dA_s \dots 4$$

$$S^\sigma dT + \sum_{i=1}^C n_i^\sigma d\mu_i + A_s d\sigma = 0 \dots 5$$

The Gibbs adsorption equation is obtained by reorganising eq.-5 and using eq.-1

$$D\sigma = -\frac{S^\sigma}{A_s} dT - \sum_{i=1}^C \Gamma_i d\mu_i \dots 6$$

$$n_X d\mu_X + n_Y d\mu_Y = 0 \quad \text{i.e.} \quad \sum_i n_i d\mu_i = 0 \dots 7$$

Changes in the chemical potential of the two components of the adsorbate due to a change in mole fraction are related by eq.-7 as for solid–gas and liquid–gas interfaces, where β is a gas phase eq.-6 may be more simplified if the adsorbate comprises only two components, X and Y, since changes in the chemical potential of the two components of the adsorbate due to a change in mole fraction are related by

$$d\mu_X = -\frac{x_Y}{x_X} d\mu_Y \dots 8$$

We get at constant temperature by substituting eq.-8 into eq.-6.

$$-\left(\frac{d\sigma}{d\mu_Y}\right)_T = \left[\Gamma_Y - \left(\frac{x_X}{x_Y}\right) \Gamma_X\right] \dots 9$$

The mole fractions of X and Y in the adsorbate α are x_X and x_Y respectively. This equation can be improved further. Since the location of the Gibbs dividing surface affects the adsorption Γ , it's simpler to describe a new function, relative adsorption, that isn't affected by the dividing surface. Eq.-1 defines the absorption of component i at the interface as

$$\Gamma_i = \frac{n_i^\sigma}{A_s} = \frac{1}{A_s} (n_i - n_i^\alpha - n_i^\beta) = \frac{1}{A_s} (n_i - c_i^\alpha V^\alpha - c_i^\beta V^\beta) \dots 10$$

The amounts of i in the two phases adjacent to the interface are $c_i^\alpha = \frac{n_i^\alpha}{V^\alpha}$ and $c_i^\beta = \frac{n_i^\beta}{V^\beta}$, and the amounts of these phases are V^α and V^β . Because eq-10 can be rewritten in terms of total volume as

$$\Gamma_i = \frac{1}{A_s} [n_i - c_i^\alpha V - (c_i^\beta - c_i^\alpha) V^\beta] \dots 11$$

Component A's adsorption can be expressed as

$$\Gamma_X = \frac{1}{A_s} [n_X - c_X^\alpha V - (c_X^\beta - c_X^\alpha) V^\beta] \dots 12$$

By combining eq.-11 and eq.-12, V^β can be eliminated eq.-12. As a result, we get the following crucial expression:

$$\Gamma_i - \Gamma_X \left(\frac{c_i^\alpha - c_i^\beta}{c_X^\alpha - c_X^\beta} \right) = \frac{1}{A_s} \left[(n_i - c_i^\alpha V) - (n_X - c_X^\alpha V) \left(\frac{c_i^\alpha - c_i^\beta}{c_X^\alpha - c_X^\beta} \right) \right] \dots 13$$

The advantage of this expression is that, while each component's adsorption is dependent on the Gibbs dividing surface, the right-hand side is unaffected by its position. As a result, the relative adsorption of component Y with respect to component X can be defined as follows:

$$\Gamma_Y^{(X)} = \Gamma_Y - \Gamma_X \left(\frac{c_Y^\alpha - c_Y^\beta}{c_X^\alpha - c_X^\beta} \right) \dots 14$$

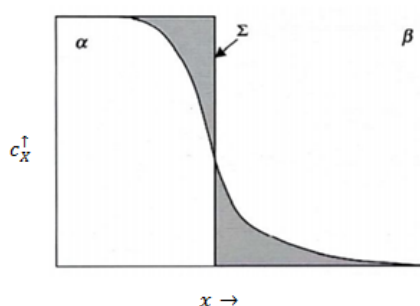

Figure 2: Component X concentration across an interface is depicted schematically. Because the algebraic sum of the two shaded areas with opposite signs is zero, the Gibbs dividing surface gives zero adsorption of component X.

We can choose the position of Σ to correspond to $\Gamma_X = 0$ because $\Gamma_Y^{(X)}$ is independent of the position of Σ , as shown in Fig.-2 for a schematic two-dimensional interface [1-4]. The adsorption of X is zero in the two shaded areas above and below the interface. Remember that the direction

of the Gibbs dividing surface is arbitrary only for planar surfaces, so we'll stick to planar surfaces for the rest of here.

Surfaceseparation and relative adsorption

At constant temperature, we can now use relative adsorption to characterise a two-component structure. For $\Gamma_X = 0$, the relative adsorption of Y with respect to X is given by as eq-9.

$$\Gamma_Y = \Gamma_Y^{(X)} = - \left(\frac{\partial \sigma}{\partial \mu_Y} \right) T \dots 15$$

As a result, the difference of surface tension with chemical potential determines β adsorption at the interface.

Many adsorption calculations involving liquid solutions are based on eq-15. When $\left(\frac{\partial \sigma}{\partial \mu_Y} \right) T$ is negative, Γ_Y is positive, and the solute concentration at the interface is too high. For $\left(\frac{\partial \sigma}{\partial \mu_Y} \right) T > 0$, Γ_Y is negative, suggesting a solute deficiency at the interface. In other words, at the surface, solutes that lower surface tension are enriched.

The partial pressure of component Y has a direct effect on its relative adsorption. Consider the binary system X–Y, in which $\Gamma_X = 0$ and Y is an ideal gas with p_Y partial pressure. The chemical potential of Y can be expressed in terms of Y's partial strain, which is also true for Y's relative adsorption.

$$\Gamma_Y = \Gamma_Y^{(X)} = - \frac{1}{RT} \left(\frac{\partial \sigma}{\partial \ln p_Y} \right) T \dots 16$$

The surface behaviour of the impurity Y, j_Y , is known as the slope of the surface tension or energy versus composition at infinite dilution and is also used to describe the effect of an impurity on the surface energy:

$$j_Y = - \left(\frac{\partial \sigma}{\partial x_Y} \right) x_{X \rightarrow 1} \dots 17$$

Using the Gibbs absorption equation and Henry's law as a guide by eq-18

$$\begin{aligned} p_i &= x_i p_i^* \dots 18 \\ j_Y &= - \frac{1}{RT} \left(\frac{\partial \sigma}{\partial x_Y} \right) x_{X \rightarrow 1} \\ &= - \frac{1}{RT} \left(\frac{\partial \sigma}{\partial \mu_Y} \right) x_{X \rightarrow 1} \left(\frac{\partial \mu_Y}{\partial x_Y} \right) x_{X \rightarrow 1} \dots 19 \\ &= + \frac{1}{RT} \Gamma_Y^X \left(\frac{\partial \mu_Y}{\partial x_Y} \right) x_{X \rightarrow 1} \\ &= \Gamma_Y^{(X)} \left(\frac{\partial \ln a_Y}{\partial x_Y} \right) x_{X \rightarrow 1} \end{aligned}$$

j_Y is considered to be finite in experiments. Henry's law for surfaces refers to the slope of relative adsorption versus composition, which is therefore finite. The surface behaviour of electronegative elements on metallic surfaces increases significantly, often to the order of 10^3 .

This means that even trace quantities of these elements have a substantial influence on the surface energy, necessitating the use of ultrapure systems for the analytical determination of stable surface energies[1-4].

Fig.-3 demonstrates the influence of composition on σ , with an emphasis on the dilute limit, for a few structures. These example structures should be required to have a high standard of separation.

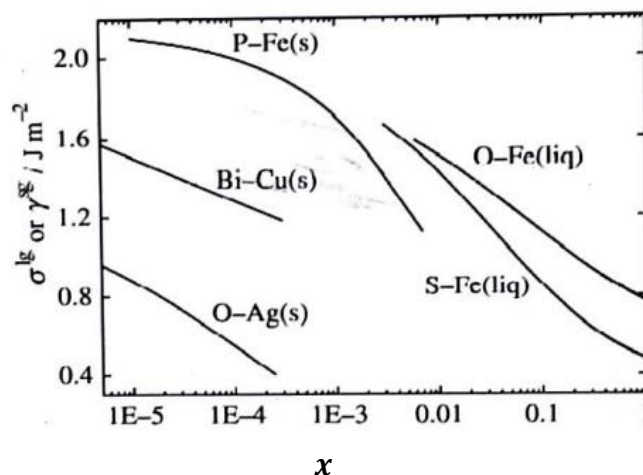

Figure 3: Surface tension in solid Fe, Cu, and Ag near their melting temperatures [5] and liquid Fe at 1550–1600 °C [2] as a function of concentration for certain surface-active organisms

Physically, this condition refers to solute atoms of large positive size misfits and/or large positive mixing enthalpies, and hence these solutes can readily separate to the surface. Surface-active organisms are substances that have a significant impact on interfacial energy even at low concentrations. Oxygen, sulphur, and other group 16 elements are typically high surface-active species for most metals. Similarly, the addition of small quantities of other elements with the opposite acid–base properties have a significant impact on the surface tension of liquid oxides or halides. The surface tension of silicates, for example, can be quickly adjusted by adding simple oxides such as alkali or alkali earth metal oxides.

The difference in surface tension with composition is much smaller in most structures. Fig.-4 depicts data for a few binary liquids. These structures are likely to have a low level of separation.

Isotherms of adsorption

We're looking at the complex equilibrium between gas-phase molecular species and adsorbed gas species on a rock. Find the following quasi-chemical equilibrium between the gaseous species Y , Y_g , and the available sites on the adsorbate's surface.

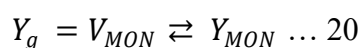

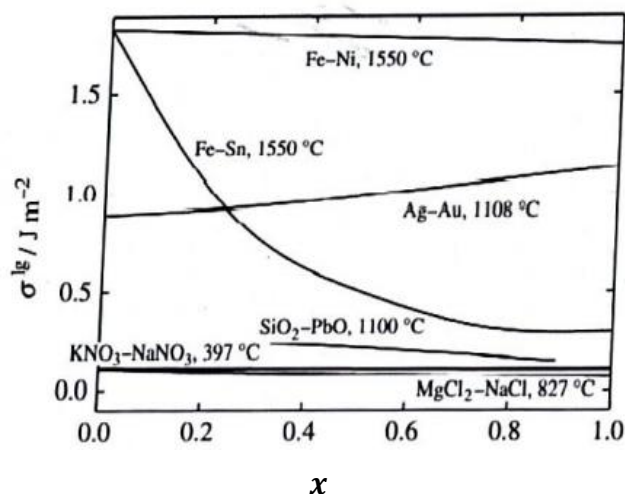

Figure 4: Surface stress of certain binary metals [6], oxide [7], and salt structures [8,9] as a function of composition

The available empty sites and surface sites occupied by Y of the first monolayer on a solid absorbate are represented by V_{MON} and Y_{MON} , respectively. The ratio of the rate constants for k_a for adsorption and k_d for desorption eq.-21 gives the equilibrium constant K_L for the reaction.

$$K_L = \frac{k_a}{k_d} = \frac{\Gamma_Y}{a_Y^g(\Gamma_Y^{sat} - \Gamma_Y)} \dots 21$$

where Γ_Y is Y's surface adsorption, $\Gamma_Y^{sat} - \Gamma_Y$ is the concentration of vacant sites in the monolayer, and a_Y^g is Y's gas phase action. Eq.-21 can be converted into the Langmuir adsorption isotherm [10] by adding the fractional coverage of the adsorbate surface θ .

$$\frac{\frac{\Gamma_Y}{\Gamma_Y^{max}}}{\frac{1-\Gamma_Y}{\Gamma_Y^{max}}} = \frac{\theta}{1-\theta} = K_L a_Y \dots 22$$

The maximum adsorption is given by Γ_Y^{max} . Adsorption cannot go beyond monolayer coverage in this simplest biologically practical adsorption isotherm, all sites are identical, and a molecule's ability to adsorb is independent of the occupation of neighbouring sites, i.e., there are no reciprocal interactions. Fig.-5 depicts typical adsorption isotherms for various K_L values.

The Langmuir model is generalised by [11] to incorporate interactions between adsorbed atoms/molecules. The model has now evolved into

$$K_L a_Y^\beta = \frac{\theta}{1-\theta} \exp \left[-2 \left(\frac{z\omega}{k_Y T} \right) \theta \right] \dots 23$$

Where z denotes the number of closest neighbours inside the surface layer, ω denotes the normal solution parameter, and a_Y^β denotes the operation of Y in β . The Fowler-Guggenheim adsorption is reduced to the Langmuir isotherm for $\omega = 0$. A significant advancement in adsorption science was the incorporation of the principle of multilayer adsorption into the treatment of monolayer adsorption.

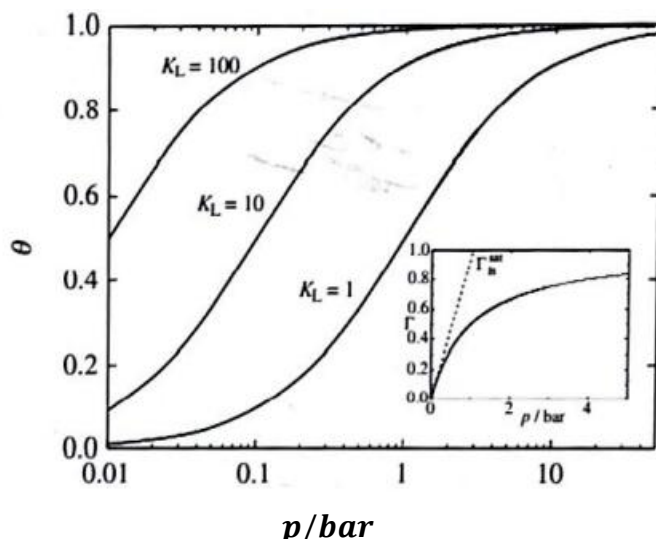

Figure 5: The Langmuir adsorption isotherm is accompanied by adsorption isotherms

The term “BET” hypothesis is coined by [12]. The process of a gas adsorbing on a solid surface is defined by eq.-24

$$\frac{1}{m_X(p_0 - p)} = \frac{1}{m_{MON} C} + \frac{C-1}{m_{MON} C} \left(\frac{p}{p_0} \right) \dots 24$$

Where m_X denotes the overall amount of gas adsorbed and m_{MON} denotes the amount of gas adsorbed per monolayer. The adsorbent's pressure and saturation pressure are p and p_0 , respectively, and C is a constant. A straight line with intercept $\frac{1}{m_{MON} C}$ and slope $\frac{(C-1)}{m_{MON} C}$ can be drawn by plotting $\frac{p}{[m_X(p_0 - p)]}$ versus $\frac{p}{p_0}$. A linear regression of experimental points of m_X versus $\frac{p}{p_0}$ will then be used to derive the values of C and m_{MON} . The surface area of the solid can be determined from m_{MON} using the mean area per molecule adsorbent. This procedure is widely used to measure the specific surface area of porous materials.

Since it relies on interactions between adsorbent molecules/atoms and surface rearrangements leading to the creation of new chemical bonds, the enthalpy of adsorption is found to be a property of fractional surface coverage θ in experiments. As the composition of the adsorbed layer varies, the enthalpy of adsorption will change unexpectedly in certain situations, such as CO adsorption on single crystal surfaces of metals [13]. Although precise enthalpies of adsorption are difficult to determine, and recorded values often differ from one laboratory to the next, consistent patterns in enthalpies of adsorption are frequently observed. When going from left to right along a period, the enthalpy of adsorption of gases like CO, H₂, N₂, and NH₃ on transition metals decreases [13]. The low-coverage heats of adsorption as metals are primarily in two-dimensional islands coincide with the bulk sublimation enthalpy of the adsorbent for metals on metal oxides, as exemplified by Cu on the (100) surface of MgO. At poor coverage, this

means that covalent metal–Mg bonding governs the relationship [14]. The enthalpy of adsorption exceeds the enthalpy of Cu sublimation after adsorption beyond the first monolayer. Just a few systems have reliable evidence on the enthalpy of adsorption, and a recent study [15], which indicates that particle size has a much greater impact on the energetics.

References:

1. Howe J. M., *Interfaces in Materials*. New York: John Wiley and Sons, 1997.
2. Jaycock M. J. and Parfitt G. D., *Chemistry of Interfaces*. John Wiley and Sons, New York, 1981.
3. Lyklema J., *Fundamentals of Interface and Colloid Science, Vol. 1: Fundamentals*. London: Academic Press, 1991.
4. Somorjai G. A., *Introduction to Surface Chemistry and Catalysis*. New York: John Wiley and Sons, 1994.
5. Hondros E. D., in *Precipitation in Solids* (Russel K.C. and Aaronson eds. H. I.). Warrendale, PA: The Metallurgical Society of AIME, 1978.
6. Murr L. E., *Interfacial Phenomena in Metals and Alloys*. Reading, MA: Addison-Wesley, 1975.
7. Shartsis L., Spinner S. and Smack A. W., *J. Am. Ceram. Soc.* 1948, 31, 23.
8. Jans G. J., Krebs U., Siegenthaler H. F. and Tomkins R. P. T., *J. Phys. Chem. Ref. Data*, 1972, 1, 680.
9. Jans G. J., Tomkins R. P. T., Allen C. B., Downey Jr J. R., Gardner G. L. and Krebs U., *J. Phys. Chem. Ref. Data*, 1975, 4, 1117.
10. Langmuir I., *J. Am. Chem. Soc.* 1918, 40, 1361.
11. Fowler R. and Guggenheim E. A., *Statistical Thermodynamics*. Cambridge: Cambridge University Press, 1939, p. 430.
12. Brunauer S., Emmett P. H. and Teller E., *J. Am. Chem. Soc.* 1938, 60, 309.
13. Somorjai G. A., *Chemistry in Two Dimensions: Surfaces*. Ithaca, NY: Cornell University Press, 1981.
14. Campbell C. T. and Starr D. E., *J. Am. Chem. Soc.* 2002, 124, 9212.
15. Campbell C. T., Parker S. C. and Starr D. E., *Science* 2002, 298, 811. 194 6 Surfaces, interfaces and adsorption.

CYCLODEXTRIN AND ITS APPLICATION IN CHEMISTRY

Simanchal Dash

Department of Chemistry,
Roland Institute of Technology,
Berhampur, Odisha, India

Corresponding author E-mail: dash.simanchal73@gmail.com

Abstract:

Cyclodextrins (CD) has an important place in organic synthesis due to its combining properties with other molecules. Out of all the significant properties of cyclodextrins, the inevitable one is formation of inclusion complex with less water soluble drugs. Solubility of drug can be enhanced by inclusion formation with cyclodextrin and for this purpose different methods can be used. To improve the aqueous solubility, dissolution properties and bioavailability of poorly soluble drugs different complex formation methods are used. Cyclodextrins are cyclic oligosaccharides acting as a complex formation agent to form inclusion complex with drugs. The nature with respect to physical and chemical properties of inclusion complex changes some extent on the substrate followed by its formation. There are a number of applications of cyclodextrins in different fields and some of them are drug delivery, pharmaceutical industry, textiles industry, foods and flavours, cosmetics etc. Out of the above mentioned fields its application is more associated with drug delivery and pharmaceutical industry because of complex formation nature. In this chapter, we have to discuss briefly about its history, chemistry, methods of inclusion formation and application of cyclodextrins in some important fields.

Keywords: Cyclodextrins, Poorly soluble, Complex formation, Drug delivery, Solubility

Introduction:

A drug delivery system deals to bring the requisite amount of drug to the required site in a definite time period both in an efficient and precise manner. Cyclodextrins (CDs) is one of the important tools developed to prevail over the adverse properties of drug molecules. These are providing a broad range of delivery tool from the old classical dosage to newly developed drugs. It also provides an extra tool for the formulation and delivery problems of some drugs. Besides cyclodextrin, their derivatives also play pivotal task in the formulation development due to their action on solubility, dissolution rate, and action towards chemical reaction and absorption towards the drug molecule ^[1, 2]. Indeed it is assumed that the simple and easier way of oral drug

delivery is drug administration with respect to greater stability, lesser bulk, precise dosage, cheaper cost of production and easier method of preparation. Hence solid oral dosage forms have better working as compared to other forms of doses [3]. It has been observed that some of the poorly water soluble drugs after oral administrations are not completely absorbed there by leading to minimize efficiency of drugs [4, 5]. A practically challenge for the chemists is solubility of drugs because forty percent of marketed drugs are classified as practically insoluble. It has been accepted that there are less possibility of its improvement during the coming decades because developed drugs exhibit poor solubility, one out of three drugs in development are poorly soluble and two out of three synthesized drugs have low solubility [6-7].

To get rid of the solubility problems different methods like evaporative precipitation into aqueous solution, alteration of pH of the drug in microenvironment, hydrotropy, solid dispersion, inclusion of complex by using cyclodextrins, micro emulsion, solid solution, eutectic mixture in addition to selective adsorption on insoluble carriers, use of surfactants, etc. are come into existence. Approximately one-third of drugs are water insoluble after developing and one-half in trials due to under privileged pharmacokinetics [8]. The less solubility drugs creates the problem of drug absorption executing not enough and erratic bioavailability and gastrointestinal mucosal toxicity [9]. Understating the fact, the bulk of recent chemical entities under development these days are planned to be used are solid dosage form that originate an helpful and reproducible *in-vivo* plasma concentration after oral administration [10]. In this chapter we have to discuss about history, chemistry, different methods of inclusion compound formation and applications of cyclodextrins (CDs) in different areas.

History of Cyclodextrins:

About 100 years ago cyclodextrins (CDs) was discovered. It is cyclic oligosaccharides belonging to family of carbohydrates. At the time when it was first discovered by A. Villiers in 1891 named as Cellulosine. F.Schardinger recognized the presence of 3 types of natural occurring cyclodextrins α , β and γ . and these were known as “Schardinger Sugars”. Pringsheim, a top researcher in Germany in this area during the time period of 1911 to establish that CDs formed stable aqueous complexes with other chemicals. With the process of enzymatic conversion, CDs are produced from starch. Different fields where cyclodextrin used are chemical, agricultural, food, environmental engineering and pharmaceuticals since last few years. On account of its unambiguous structure and the orientation of the hydroxyl groups made the CDs capable of solubilize in aqueous medium and to encapsulate the lipophilic molecules into their interior cavity [11, 12].

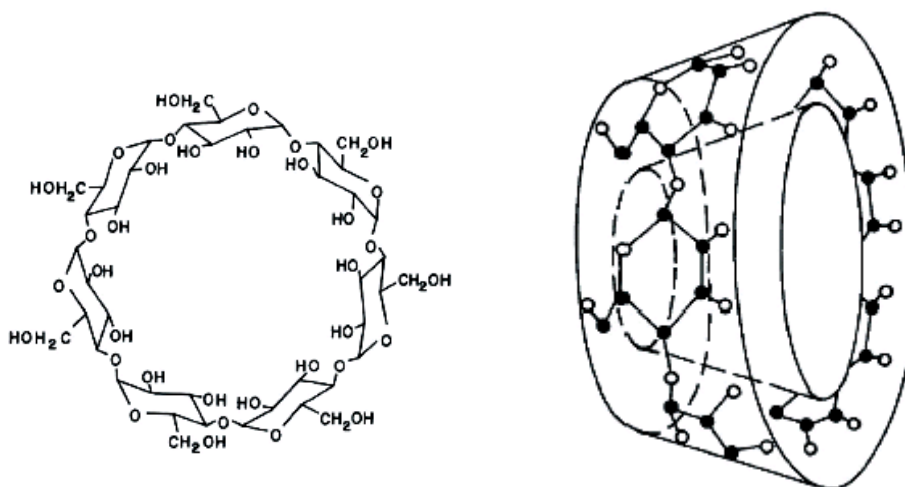
Structure and Properties:**Figure 1: The chemical structure of β -cyclodextrin molecule**

Cyclodextrin consists of (α -1, 4)-linked α -D-glucopyranose unit with a lipophilic central cavity and the structures are as shown in fig.1. On account of the chair formation of the glucopyranose units, the shape of cyclodextrin molecules is cone like and secondary hydroxyl groups extending from the wider edge and the primary groups forming the narrow edge. As a result, there is formation of a hydrophilic outer surface in cyclodextrin molecules. There are three types of natural occurring Cyclodextrin and these are α -cyclodextrin, β - cyclodextrin and γ -cyclodextrin. The natural occurring α -CD and β -CD, unlike γ -CD cannot be hydrolyzed by human salivary and pancreatic amylases but all three are subjected to fermentation by the intestinal micro flora. The glucopyranose units of 6, 7 and 8 are contained by are α -CD, β -CD and γ -CDs respectively. Their less aqueous solubility is because of strong intermolecular hydrogen bonding in the crystal state. Substitution of the H-bond forming -OH group has improved their solubility [12]. Some of the derivatives having pharmaceutical interest belong to hydroxyl propyl derivatives of β , γ and methylated β -cyclodextrins, sulfobutyl ether β -cyclodextrin etc. The three natural CDs, α -, β - and γ -CDs (with 6, 7 or 8 glucose units respectively) differ in their ring size and solubility (Table-1). With the changing of the 2- or 3-hydroxyl group marks in disturbance of the hydrogen bonding taking place around the ring of the CD molecule. The disturbance creates further interactions of these hydroxyl groups with water molecules resulting in changed solubility [13]. There is creation of a non-covalent interaction between the molecule and the CD cavity with the complex formation of molecule with cyclodextrin. This is a reversible process where the guest molecules combine and breaks from

the host CDs. The nontoxic nature of cyclodextrins is observed at level of low to moderate oral dosages. For the topical and oral formulations natural cyclodextrin and its derivatives are used where as in parenteral formulations only α -cyclodextrin and the hydrophilic derivatives of β - and γ -cyclodextrin can be used. The γ -cyclodextrin is not well suited for parenteral formulations and forms visible aggregates in aqueous solution ^[14]. Lipophilic cyclodextrin derivatives like methylated cyclodextrins, are to some extent absorbed from the gastrointestinal tract into the systemic circulation and have been shown to be toxic after parenteral administration. The potential toxicity of methylated β -cyclodextrin is limited by its oral administration. Some important properties of different derivatives of cyclodextrin are listed in table.1

Table 1: Chemical and physical properties of α , β , γ and δ -cyclodextrin

Physicochemical properties	α	β	γ	δ
No. of glucopyranose units	6	7	8	9
Molecular weight	972	1135	1297	1459
central cavity diameter (A°)	4.7-5.3	6.0-6.5	7.5-8.3	10.3-11.2
Water solubility at 25°C (g/100 mL)	14.5	1.85	23.2	8.19

Different ways for making inclusion complexes:

Various methods have been developed for making inclusion complexes, some of them discussed here.

1. Physical blending / Grinding method:

Physical blending process can be done either by laboratory method or industrial method. In the first method, a mixture of drug and cyclodextrin are taken in a mortar followed by grinding. On the second method, complex can be prepared by extensive blending of drug with cyclodextrin for time period of thirty minutes in a rapid mass granulator ^[15].

2. Kneading method:

It is a common and simple method for preparing inclusion complex at a low cost. At the beginning of the method a little amount of water is taken with cyclodextrin to make its paste and the drug is added with small amount of ethanol or with little solvent. Solvents get evaporated after completion of grinding and a complex in powder form is obtained. On laboratory methods, kneading can be performed with the help of mortar and pestle. On the other hand for getting the complex on larger scale kneading can be done by utilizing the extruders and other machines ^[16-17].

3. Co-precipitation:

To carry out the method, prepare cyclodextrin solution in water and then add the drug with constant stirring in it. By heating the solution at high temperature some more cyclodextrin of up to 20% can be dissolved in solution. Cooling of cyclodextrin and guest solution to be done before a precipitate is formed. Collection of the precipitate can be done by decanting the solution followed by centrifuging and washing the solution. A dissolution characteristic of inclusion complex of Gliclazide-Beta- cyclodextrin and solid state characterization has been studied ^[18].

4. Solution/solvent evaporation method:

Drug and CD's are dissolving separately in two mutually miscible solvents. Mixing of both the solution leads to molecular dispersion of drug and complexing agents. At the end, evaporating the solvent under vacuum to get solid powders of inclusion compound. Usually, the aqueous solution of CD's is mixed with alcoholic solution of drugs. The combining mixture is stirred for 24 hours and then evaporated at vacuum at 45⁰C, the dried mass is pulverized and passed through a 60-mesh sieve.

5. Neutralization method:

This involves with dissolving the drug in alkaline solution of sodium or ammonium hydroxide and mixed with the aqueous solution of cyclodextrin. The formed solution is then neutralized with hydrochloric acid till attaining the equivalence point. A white precipitate is formed at this point corresponding to the formation of inclusion compound. The formed precipitate is filtered and dried until free from chlorine and stored in desiccators. The improvement of solubility of Piroxicam by complexation with beta-cyclodextrin has been studied ^[19].

6. Milling/Co-grinding techniques:

With the help of mechanical device grinding and milling of drug and CD has to be taken place for the preparation of inclusion complex. On the other hand, ball milling process is can be utilized for preparing drug-CD binary system. This method better compared to the other methods in view of economic and environmental point since it does not require any toxic reagent.

7. Atomization/Spray drying method:

Spray drying is a common method in pharmaceuticals to produce a drug powder from a liquid phase. It is most employed method to produce a inclusion complex from a solution. In this method, the mixture is pass to a first elimination system propitiate a solvent and shows a maximum efficiency in complex formation. In addition to this the product obtained by this method produce the particle in controlled manner which once improves the dissolution rate of

drug in the complex form. There is a formation of complex between budesonide and cyclodextrin and their particle aerodynamic characterization of the complex solid form for dry powder Inhalation has been studied ^[20].

8. Lyophilization/ Freeze drying technique:

In order to get a porous and amorphous powder with high degree of interaction between drug and cyclodextrin lyophilization/freeze drying technique is considered as an appropriate method ^[21]. Starting with the process of primary freezing the solvent system from the solution is eliminated and subsequent drying of the solution containing both drug and cyclodextrin at reduced pressure is carried out. Using this method, the complex can be prepared successfully from thermo labile substances. The limitations of this technique are it takes long time and yield poor flowing product.

9. Micro wave irradiation method:

In this method, microwave oven is used to carrying microwave irradiation reaction between drug and complexing agent. In a fixed molar ratio drug and CD are dissolved in a mixture of water and organic solvent. The mixture is reacted for a time of 1 or 2 minutes at a temperature of 60⁰ C in the microwave oven. After completion of reaction, sufficient amount of solvent mixture is added to the above reaction mixture to remove the residual uncomplexed free drug and CD. Separation of precipitation has to be carried by using whatmann filter paper and dried in vacuum over at 40⁰C for 48 hours ^[22].

10. Supercritical anti-solvent technique:

In this technique, CO₂ is used as anti-solvent for solute where as solvent with respect to organic solvent. The use of super critical CO₂ is advantageous because of its low critical temperature and pressure making it attractive for processing heat labile pharmaceuticals. It is also non-toxic; non-flammable, inexpensive and easier to remove from polymeric material when the process is complete although small amount of it is trapped inside it. Supercritical particle generation processes are new and capable route for improving bioavailability of pharmaceutically active compounds ^[23].

Application of Cyclodextrins:

[A] Foods and flavours:

The molecules possessing fats, flavours and colours form inclusion complexes with cyclodextrins and food formulations for flavour protection or flavour delivery purpose also cyclodextrins are used. Mainly natural and artificial flavours are present in liquid forms and the complex formation with cyclodextrin is used for flavour protection through conventional encapsulation technologies. These are reported to have a texture-improving effect on pastry and

on meat products. Some of the properties like reduction in bitterness, stabilizing the flavours, reducing ill smell and taste are to be performed by cyclodextrin. Some emulsions can be stabilised with α -cyclodextrin are mayonnaise, margarine or butter creams. With the use of cyclodextrin cholesterol level from milk can be removed or lowered ^[24-25]. It being acted molecular encapsulates, protect the flavour in different food-processing methods like freezing, thawing and microwaving. As an agent like encapsulant β -CD maintains the flavour quality and quantity to be conserved at a larger extent and also long duration of time in the food items. Since more than two decades CDs have been approved as 'modified starch' for food applications and in Japan it serving as masks odours in fresh food and stabilises fish oils. On account of its low toxic nature, Hungary has been approved γ -cyclodextrin for use in certain applications. The complexation of CDs with sweetening agents aspartame stabilises as well as improves its taste. It also abolishes the bitter aftertaste of other sweeteners like stevioside, glycyrrhizin and rubusoside. CD itself is a promising new sweetener. The bitterness of citrus fruit juices is a major problem in the industry caused by the presence of limonoids and flavanoids. Cross-linked cyclodextrin polymers works by removing these bitter components by inclusion complexes. For preparation of foodstuffs CDs can be applied in various ways. For example, highly branched CDs are used in are used in pharmaceuticals ^[26]. Cyclodextrin on treatment with fruits and vegetable juices removes phenolic compounds, which makes enzymatic browning. The colourless polyphenols changes to colour compounds with the help of polyphenol-oxidase in juices and removal of polyphenoloxidase from juices have carried out by addition of CDs.

[B] Agricultural and chemical industries:

The chemicals used in agriculture like herbicides, insecticides, fungicides, repellents, pheromones and growth regulators form complexes with cyclodextrins. It can be also used to delay germination of seed. Some of the amylases that degrade the starch supplies of the seeds are inhibited when grain is mixed with β -cyclodextrins. At the beginning the plant grows more slowly, but after some time this is largely compensated by an enhanced plant growth yielding a better harvest ^[24]. The role of cyclodextrin in environmental science also cannot be neglected specially it can be used in terms of solubilisation of organic contaminants, enrichment and removal of organic pollutants and heavy metals from soil, water and atmosphere. In case of water treatment also CDs increases the stabilising action, encapsulation and adsorption of contaminant. Toxic substances can be separated from industrial effluent by using CDs by inclusion complex formation methods. In the mother liquor of the insecticide trichlorfon, the uncrystallisable trichlorfon can be converted into a β -CD complex and in a single treatment 90%

of the toxic material is removed [24-25]. On the treatment of wastewaters with β -CD environmentally unacceptable aromatic compounds like phenol, *p*-chlorophenol and benzene reduced and it come to acceptable limit. By the way, it can be also used to scrub gaseous effluent from organic chemical industries [24-25]. CDs has the potential to increase the soluble nature of the hydrocarbon for the process of biodegradation and bioremediation, CDs also reduce the toxicity by increasing in microbial and plant growth. β -cyclodextrins increase speed of degradation of all types of hydrocarbons that influences the growth kinetics, yielding higher biomass yield and better deployment of hydrocarbon for carbon and energy source

[C] Cosmetics, personal care and toiletry:

The applications of cyclodextrin in cosmetic preparation includes toothpaste, paper towels, tissues, skin creams, liquid and solid fabric softeners, etc These characteristics of cyclodextrins or their derivatives make them appropriate for applications in analytical chemistry, in pharmaceuticals, in food, in agriculture, and toilet articles etc. [27]. CDs used in silica-based toothpastes enhance the presence of triclosan (an antimicrobial) by cyclodextrin complexation and forming threefold enhancement of triclosan availability. The performance and shelf life of self-tanning emulsions or creams are improved by incorporating CD with it. Some of the other applications where CDs are used are in toothpaste, paper towels, tissues and underarm shields ,skin creams, liquid and solid fabric softeners, [24]. The talcum powder with the presence of CDs stabilises the fragrance against the loss by evaporation and oxidation over a long period of time. The antimicrobial efficiency of the product is also increased [25]. The main benefits of CDs in bioconversion process are stabilisation, flavour protection and flavour delivery in lipsticks, water solubility and enhanced thermal stability of oils ,odour control, and process improvement upon conversion of a liquid ingredient to a solid form etc.,

[D] Drug Delivery systems:

A drug should have a minimum level of water solubility to be readily reach to the cellular membrane, but it should be hydrophobic sufficient to cross the membrane. The key properties of cyclodextrins is their potential to increase drug delivery through biological membranes. But the cyclodextrin molecules having molecular mass nearly 1000 to 1500, with a hydrated outer surface and under normal conditions, cyclodextrin molecules will only permeate biological membranes with substantial difficulty [2]. Usually it is considered that cyclodextrins act as true carriers by maintaining the hydrophobic drug molecules in solution and delivering them to the surface of the biological membrane where they partition into the membranes like skin and mucosa. The comparatively lipophilic membrane has a less affinity for the hydrophilic cyclodextrin molecules and as a result they remain in the aqueous membrane exterior, e.g. the

aqueous vehicle system like salvia or the tear fluid.etc. Alcohols and fatty acids acting as conventional penetration enhancers disrupt the lipid layers of the biological barrier. At the mean while, cyclodextrins, act as penetration enhancers by increasing drug availability at the surface of the biological barrier. For example, cyclodextrins have been used successfully in aqueous dermal formulations ^[28], an aqueous mouthwash solution ^[29], nasal drug delivery systems ^[30] and several eye drop solutions ^[31-33]. There are also some more applications for cyclodextrins in the pharmaceuticals field. The key among them is combination of α - or β -cyclodextrin enhances the water solubility of several poorly water-soluble substances. As a consequence of this, it results in improved bioavailability, increasing the pharmacological effect allowing a reduction in the dose of the drug administered. .

Conclusion:

There are many drugs are which are poorly water soluble and their efficiency in our body can be increased only after completely solubilisation with water. So it is assumed that the solubility enhancement techniques made a good role for the proper functioning of drug. Cyclodextrin act as useful solubilise enabling both solid/liquid oral dosage forms and are capable to change the physicochemical properties like solubility, particle size, crystal habit, thermal behaviour. For preparing drug and CD inclusion compounds permeation of insoluble drugs through various biological membranes to be enhanced. From the research it has been found that both humans and animals, cyclodextrins can be used to progress the drug delivery of any kind of drug formulations. Hence cyclodextrins act as both solubilisers and permeation enhancers. In the coming days, it is expected that cyclodextrins can solve many properties like increasing solubility, bioavailability, stability etc. by drug delivery method through the complexation techniques. It is the uniqueness property of cyclodextrins to form inclusion complexes with many guest molecules to form complete molecule or a part of it into the cavity of it with the encapsulation method. This type of encapsulation properties affects most of physicochemical properties of the guest molecules. On account of these properties it results the growing importance of the applications of cyclodextrins in food, pharmaceutical, agriculture and chromatographic techniques.

Referances:

1. Loftsson T and Brewster ME, (1996):Pharmaceutical applications of cyclodextrins., J. Pharm. Sci. 85: 1017–1025.
2. Rajewski RA and Stella VJ, (1996) Pharmaceutical applications of cyclodextrins. 2. in vivo drug Delivery. J. Pharm. Sci.85:1142-69.
3. Sugawara M, Kadomura S, Xin H, Takekuma Y, Khorii N and Miyazaki K, (2005):The use of an in vitro dissolution and absorption system to evaluate oral absorption of two weak bases in pH-independent controlled-release formulations, Eur. J. Pharm.Sci.,26: 1-8.
4. Van Drooge DJ, Hinrichs WLJ, Visser MR and Frijlink HW, (2006): Characterization of the molecular distribution of drugs in glassy solid dispersions at the nano-meter scale, using differential scanning calorimetry and gravimetric water vapour sorption techniques. Int. J. Pharm.301:220-29.
5. Ponton CW, (2006) Formulation of poorly water-soluble drugs for oral administration: Physicochemical and physiological issues and the lipid formulation classification system. Eur. J. Pharm. Sci.29: 278-87.
6. Takagi T. (2006): A Provisional Biopharmaceutical Classification of the Top 200 Oral Drug Products in the United States, Great Britain, Spain and Japan, Molecular Pharmaceutics 3(6): 631–643.
7. Dubin CH,(2006): Formulation Strategies for Poorly Soluble Drugs, Drug Delivery Technology ,6(6): 34–38.
8. Lobenberg R and Amidon GL(2000) Modern Bio-availability, Bio-equivalence and Biopharmaceutics ClassificationSystem; New Scientific Approaches to International Regulatory Standards, Eur. J. Pharm. Biopharm,50:3-12.
9. Rinaki E, Valsami G and Macheras P. (2003): Quantitative Biopharmaceutics Classification System; the central role of dose/solubility ratio. Pharm. Res.,20:1917.
10. Adley AN, Lima Jose LS, Sabcinho Roberto AC, Correa JR and Pedro JRN(2008): Alternative Technologies to Improve Solubility of Poorly Water Soluble Drugs. Am. J. Pharm.,27(5):789-97.
11. Vekama K,(2004):Design and Evaluation of Cyclodextrin- Based Drug Formulation. Chem.Pharm.Bull.,52 :900-15.
12. Hakkarainen B, Fujita K, Immel S, Kenne L and Sandstrom C(2005): H NMR studies on the hydrogen-bonding network in mono- α -cyclodextrin and its complex with adamantane-1-carboxylic acid, Carbohydr Res., 340: 1539–1545,

13. Mosher G. and Thompson DO,(2006): Complexation: Cyclodextrins In James Swarbrick (Ed.), Encyclopedia of Pharmaceutical Technology Third Edition (Vol 2, pp 671-1434) Informa Healthcare New York, London.
14. Szente I, Szejtli J and Kis GI (1998): Spontaneous opalescence of aqueous γ -cyclodextrin solutions: complex formation or self-aggregation., J Pharm Sci., 87: 778–781.
15. Manoj M, Nitalikar Dinesh M, Sakarkar Parag V. Jain, (2012): Journal of Current Pharmaceutical Research, 10 (1): 01- 06.
16. Cirri M, Rangoni C, Maestrelli F, Corti G and Mura P, ,(2005) Development of Fast-Dissolving Tablets of Flurbiprofen-Cyclodextrin Complexes, Drug Dev. Ind. Pharm.,1:697- 707 .
17. Cunha-Filho MSS, Dacunha-Marinho B, Torres- Labandeira JJ, Martinez-Pacheco R and Landin M, (2007): Characterization of β -Lapachone and Methylated β - Cyclodextrin Solid-state Systems...,AAPS Pharm Sci. Tech., 8:1-10.
18. Moyano JR, Blanco MJA, Gines JM and Giordano F,(1997):Solid State Characterization and Dissolution Characteristics of Gliclazide Beta-Cyclodextrin Inclusion Complexes, Int. J. Pharm.,48: 211-17.
19. Doijad RC, Kanakal MM and Manvi FV,(2007):Studies on Piroxicam-beta-Cyclodextrin Inclusion Complexes.,Indian Pharmacists.,VI: 94-98,
20. Vozzone CM and Marques HMC, (2003):Complexation of Budesonide in Cyclodextrins and Particle Aerodynamic Characterization of the Complex Solid Form for Dry Powder Inhalation.J. Incl. Phenom. Macroc. Chem., 44:111-15.
21. Cao FT, Guo J and Ping Q, (2005):The Physicochemical Characteristics of Freeze-Dried Scutellarin- Cyclodextrin Tetracomponent Complexes, Drug Dev. Ind. Pharm.,31:747-56.
22. Deshmukh SS, Potnis VV, Shelar DB and Mahaparale PR. (2007): Studies on Inclusion Complexes of Ziprasidone Hydrochloride with beta-cyclodextrin and Hydroxypropyl beta-cyclodextrin, Indian Drugs,44:677-682.
23. Fages J,Lochard H,Letourneau JJ,Sauceau M,Rodier E,(2004) Phase Behavioral Effects on Particle Formation Processes Using Supercritical Fluids,Powder Technol.,141:219-26.
24. Szejtli J.(1998): Introduction and general overview of cyclodextrin chemistry, Chem Rev., 98:1743–53.
25. Hedges RA. (1998) Industrial applications of cyclodextrins., Chem. Rev.,98:2035–44.

26. Bhardwaj R, Dorr RT and Blanchard J.(2000):Approaches to reducing toxicity of parenteral anticancer drug formulations using cyclodextrins, *J Pharm Sci Technol.*,54:233–9.
27. Singh M, Sharma R and Banerjee UC.(2002):Biotechnological applications of cyclodextrins, *Biotechnol Adv*,20:341–59.
28. Uekama K, Adachi H, Irie T, Yano T and Saita M.(1992) Improved transdermal delivery of prostaglandin E 1 through hairless mouse skin: combined use of carboxymethyl-ethyl- β -cyclodextrin and penetration enhancers, *J Pharm Pharmacol*,44:119–21..
29. Kristmundsdóttir T, Loftsson T, Holbrook WP.(1996) Formulation and clinical evaluation of a hydrocortisone solution for treatment of oral disease. *Int J Pharm*;139: 63–8.
30. Kublik H, Bock TK, Schreier H and Müller BW. (1996): Nasal absorption of 17 β -estradiol from different cyclodextrin inclusion formulations in sheep.*Eur J Pharm Biopharm*, 2:320–4.
31. Loftsson T and Stefánsson E.(1997): Effect of cyclodextrins on topical drug delivery to the eye, *Drug Devel Ind Pharm.*, 23:473–81.
32. Van Dorne H.(1993) Interaction between cyclodextrins and ophthalmic drugs. *Eur J Pharm Biopharm*; 9:133–9.
33. Jarho P, Urtti A, Pate DW, Suhonen P, Järvinen T. (1996): Increase in aqueous solubility, *Int J Pharm*, 137:209–17.

SIMULATION AND EVALUATION OF Li-Fi DATA TRANSMISSION AND RECEPTION USING LED AND PHOTODIODE

B. Gopinath*, V. K. Amala, R. Aishwarya and N. Dineshkumar

¹Department of Electronics and Communication Engineering,

Kumaraguru College of Technology,

Coimbatore-641049, Tamilnadu, India

*Corresponding author E-mail: gopinath.b.ece@kct.ac.in

Abstract:

Li-Fi (Light Fidelity) is a modern technology through which transmission of data can be achieved by sending data through a Light Emitting Diode (LED) bulb with varying intensities. Li-Fi is working as a wireless optical networking technology with LEDs for data transmission. It gives better bandwidth, efficiency and security than Wi-Fi based networking. The need of networking has increased for cellular networks. However, data transfer speed is being interrupted by limited bandwidth. Due to the reduced bandwidth available in the RF range, this tool would reach the critical threshold very soon. Compared to radio frequency communication, which is 300GHz, Li-Fi can deliver an average frequency band of 400THZ. Compared to Wi-Fi it has a data rate of greater than 10 Gbps. In operating range, it has a confined area of 10 meters. If this kind of technology is used in hospitals during emergency times, it will be very useful for easy and secure data communication. In Li-Fi technology, data from the computer is sent to RS232 level convertor and it is transferred to Li-Fi transmitter. Then, LED transmits it to another end at which the receiver is located. The receiver now receives, processes the light and gives the data to end device. The objective of this work is to simulate and evaluate the Li-Fi based communication facility to be used in hospitals with a quick and secure data communication features.

Introduction:

The data transmission and reception are normally depending on Wi-Fi and an alternate is being searched by the researchers. A perfect alternate for the data transmission is Li-Fi with more reliability. It uses the LED for the transmission of data by triggering LED as switching ON and OFF at a high speed and a very low delay which is not noticeable by the eyes. It is working by varying the light intensities and has higher bandwidth, efficiency and security compared with Wi-Fi technology [1]. Like Wi-Fi, Li-Fi is using light as a transporter instead of radio frequencies. In remote regions like Aircraft regions, Li-Fi facility can be utilized using white LED bulbs at the downlink transmitter. The optical property can work at high speeds and this

property is utilized in Li-Fi arrangement. Practically speaking, Li-Fi can result a hypothetical speed of 10 Gbps which means that one can download a high film just within 30 seconds [2]. A remote correspondence framework was proposed for information transmission using light. Various parameters considered were boundaries utilized for examination, information rate and time duration of the information sent [3]. A Li-Fi based circuit was intended to communicate information from a PC using a microcontroller in a research center [4]. Li-Fi uses light segment of the electromagnetic range to perform data transmission. Hence, the light correspondence solves the limitation of radio recurrence blockage [5]. Since the light is acting as a medium to transmit fast information, it is superior to that of Wi-Fi. Li-Fi data is transmitted as few data streams, the receiver side IR indicator can translate the data received. Similarly, at the receiver side, silicon photodiode module is used to recognize the light produced by the Li-Fi transmitter [6]. The researchers are doing innovations and preliminary examinations on Li-Fi and the application of Li-Fi tested to transmit the data from one PC to next PC. As Light Fidelity is a remote information transmission method in which LEDs are working as a transmitter to send the information remotely instead of radio recurrence as in Wi-Fi. In Li-Fi, the significant attention is given to LEDs to transmit data since they are having minimal effort [7].

Li-Fi Transmitter and Receiver Sub-systems:

Li-Fi is an inevitable technique that uses quick variations in light to communicate information. The core Li-Fi setup includes a luminosity LED which acts as a source of transmission, a device which encodes the information and a photosensitive component. The data which is to be transmitted from a personal computer is converted as ASCII format. This information is communicated by means of Universal Asynchronous Receiver-Transmitter (UART) to Recommended Standard 232 (RS232) as serial data. RS232 sends this sequential information to microcontroller where sequential information is outlined and connected to transmitter circuit. This transmitter comprises of four parts namely, level converter, Li-Fi transmitter, LED driver circuit and LED as shown in Figure 1.

The UART is a PC equipment gadget for nonconcurrent sequential correspondence in which the information organization and transmission speeds are configurable. The electric flagging levels and strategies are taken care by a driver circuit outer to the UART. This UART acts as a serial data protocol for transferring the signals from transmitter to the receiver. The RS232 standard characterizes voltages and general baud rate ranges for sequential correspondences between gadgets utilizing it. In telecommunications, RS232 is a norm for sequential paired information signals interfacing between a DTE (Data Terminal Equipment) and a DCE (Data Circuit-terminating Equipment). It is usually utilized in PC sequential ports.

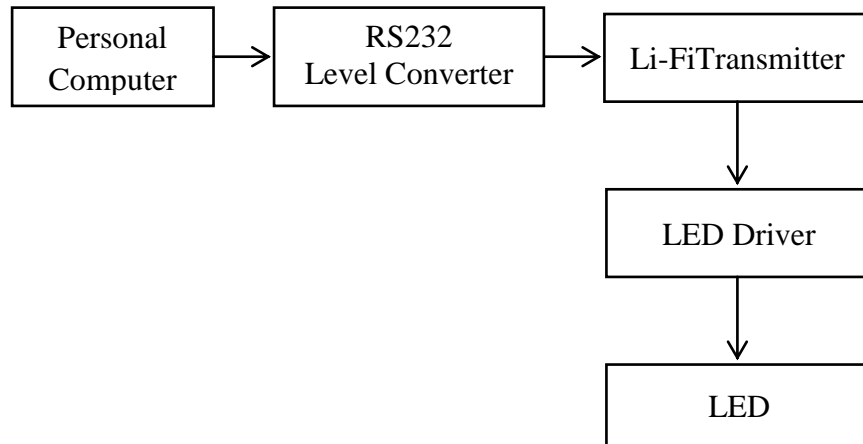

Figure 1: Components of Li-Fi Transmitting System

A driver is a circuit utilized for controlling another circuit that is used to adjust the momentum which streams through a circuit or to deal with the other required factors. The Darlington transistor (frequently called a Darlington pair) is a compound structure comprising a pair of two bipolar semiconductors (either incorporated or isolated gadgets) associated so that the current enhanced by the principal semiconductor is intensified further continuously one. This design gives an enhanced current gain than every semiconductor taken independently. The receiver circuit consists of a silicon photodiode, an amplifier and a level converter which are connected to a personal computer as shown in Figure 2. The light received by the photodiode is converted into electrical signals that are amplified by the amplifier circuit. These demodulated information are given to personal computer through an Automated Gain Control (AGC) circuit, RS232 level converter and UART.

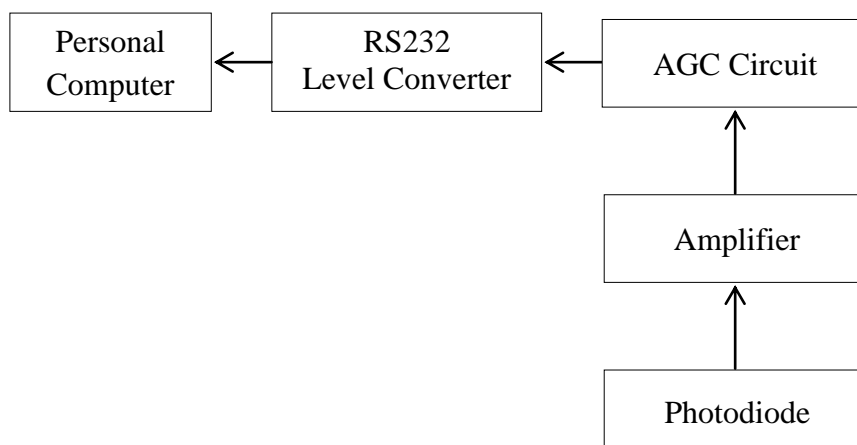

Figure 2: Components of Li-Fi Receiver System

A photodiode is a semiconductor gadget that converts light into an electrical flow. The current is created when photons are caught up in the photodiode. To enhance the weak

signals of the output of photodiode, amplifier circuit is utilized and the electrical signals are amplified. The AGC is a gain controlling circuit used in most radio collectors to balance the normal volume of various radio broadcasts. Without AGC the sound radiated from an AM radio recipient would change to an outrageous degree from a frail to a solid sign.

Simulation Results of Li-Fi System:

Figure 3 shows the entire Li-Fi system with transmitter and receiver combination. This work demonstrates the data communication using the light source through the Li-Fi technology and wireless standard.

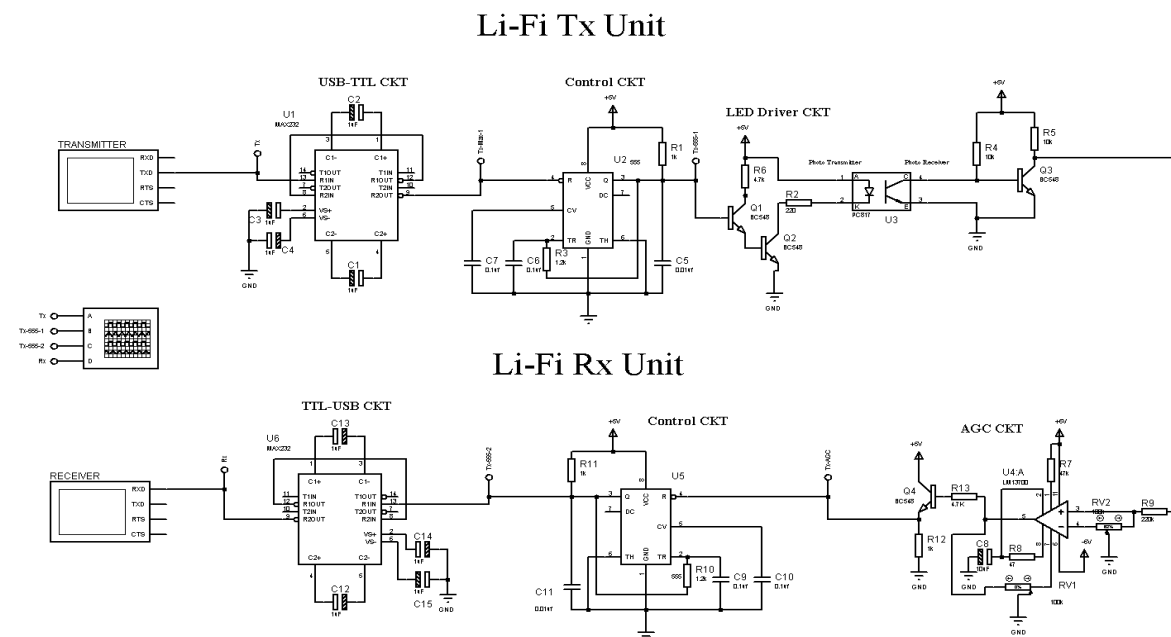

Figure 3: Combined Li-Fi Transmitter and Receiver

It is a simple one to transfer the data via Li-Fi communication method. The Li-Fi wireless communication system is a safe and secure way of transmitting image or video file in the form of light through LED to the receiver circuit. The receiver detects the light using photodiode and converts the incoming optical information into corresponding image or video file which can be viewed using an external display.

The components of transmitter and receiver sections of the Li-Fi system is simulated using Proteus software and the results are captured as shown in Figure 4.

Figures 5 and 6 show the data transmission from the transmitter and reception of the data at the receiver with a delay of 100 ms respectively. The time delay can be changed so that the data transmission rate is increased or decreased. The transmitted and received data can be viewed through multiple parts of the circuit through four output channels as shown in Figure 6.

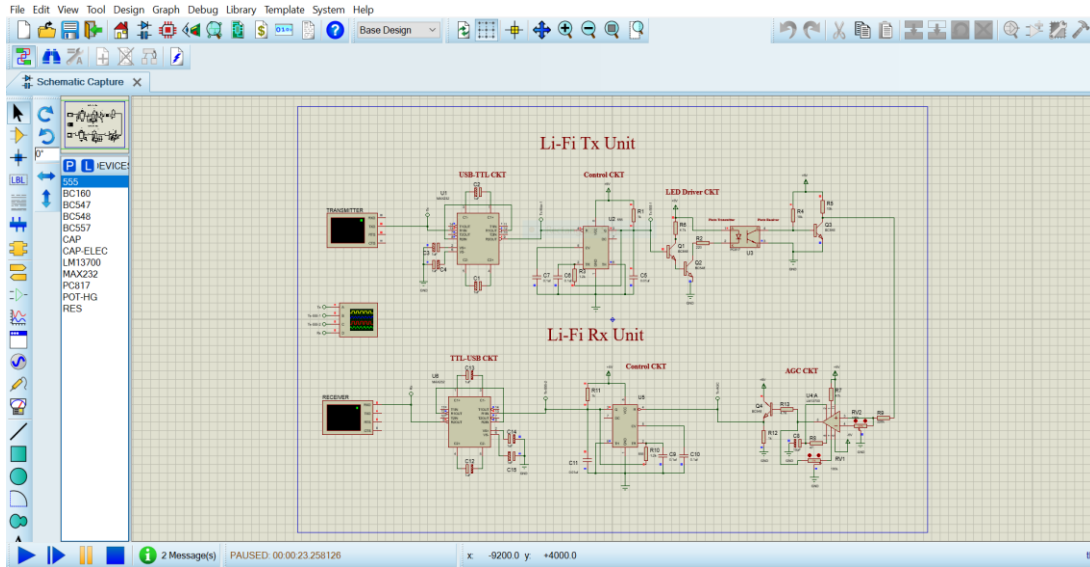

Figure 4: Simulation Results of Transmitter and Receiver Sections

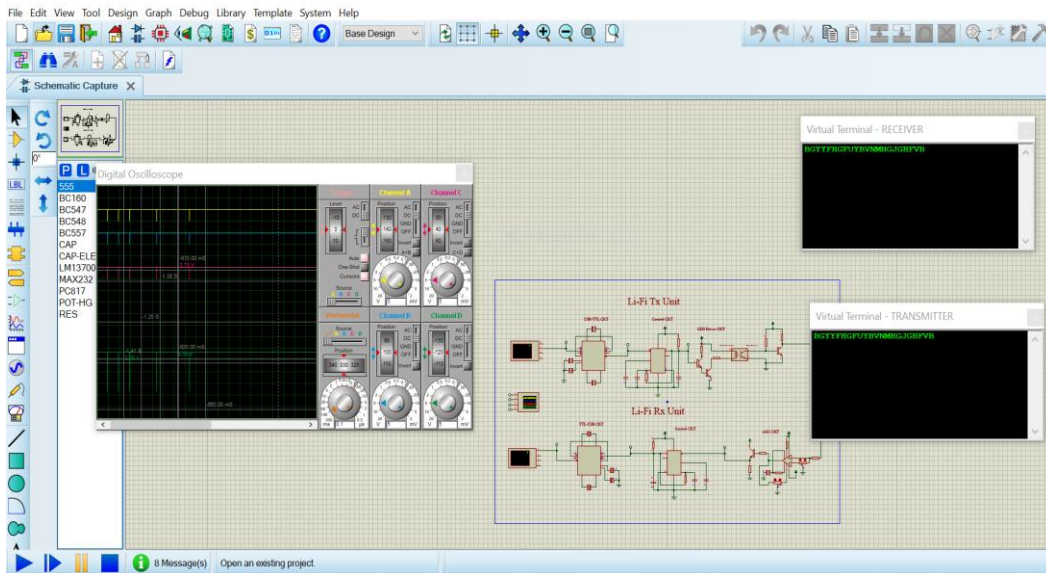

Figure 5: Simulation Results of Data Transmission

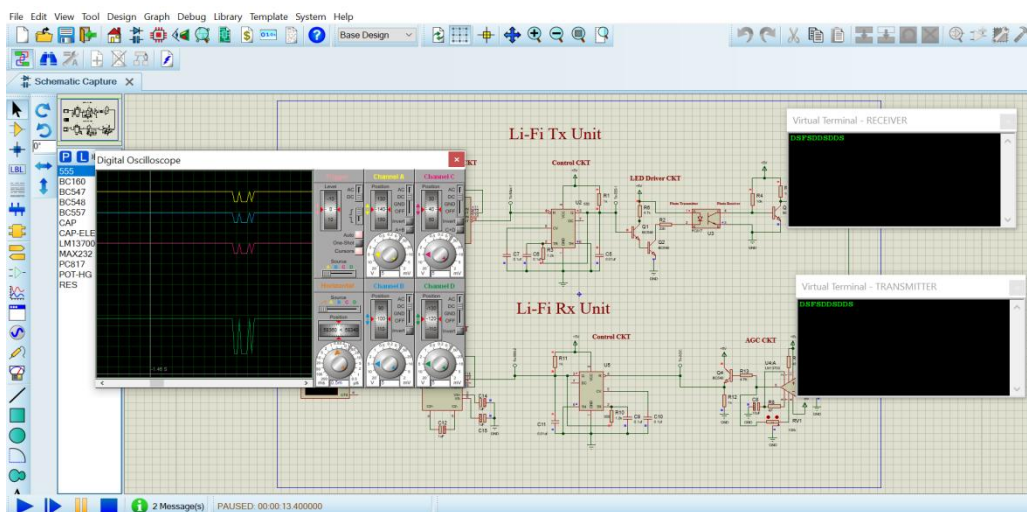

Figure 6: Simulation Results of Data Reception

Conclusion:

A PC to PC data transmission in terms of Li-Fi visible light communication has been reviewed and Li-Fi transmitter and receiver circuits have been simulated using a simulation tool. The LED was acting as a light emitting source which was used to transmit the data from a PC and the photodiode was used as a receiver of the light signals. A simple data transmission and reception can be replaced by the image files or video files transmission. The simulation results were observed by transmitting and receiving the data which are examined and encouraged. As a future work, the Li-Fi technology can be implemented using the real-time hardware system. The system can be tested by transmitting and receiving various medical images within a hospital premises so that a huge amount of time will be saved by the physicians. Also, if the Li-Fi facility is carefully designed and placed in public and commercial areas, it will be substituting and replacing a Wi-Fi hotspot.

References:

1. Chakraborty, A., Dutta, T., Mondal, S. and Nath, A., (2017): Latest advancement in Light Fidelity (Li-Fi) Technology, *International Journal of Advance Research in Computer Science and Management Studies*, 5(12).
2. Verma, P., Shekhar, J. and Asthana, A., (2015): Light-Fidelity (Li-Fi): transmission of data through light of future technology, *International Journal of Computer Science and Mobile Computing*, 4(9), 113-124.
3. Xavier, J.K., Raveen, N., Aneesh, A.R. and Sarada, M.V., (2018): Data Transfer using Light Fidelity Technology, *International Journal of Pure and Applied Mathematics*, 119(15), 903-908.
4. Borah, B., Chakrabortt, D., Deka, K. and Bora, P., (2017): Design of a Li-Fi based Data Transmission System, *International Journal of Innovative Research in Science Engineering and Technology*, 6(9).
5. Pushkala, S.P., Renuka, M., Muthuraman, V., Abhijith, M.V. and Kumar, S.S., (2017): Li-Fi Based high data rate visible light communication for data and audio transmission, *International Journal of Electronics and Communication Engineering*, 10(2), 83-97.
6. Madhuri, G., Anjali, K. and Prabha, R.S., (2020): Transmission of data, audio and text signal using Li-fi technology, In *IOP Conference Series: Materials Science and Engineering*, 872(1), 012010, IOP Publishing.
7. Ahlawat et al. (2016): Advanced light fidelity (li-fi) system, *International Research Journal of Engineering and Technology*, 3(4), 2632-2635.

**COMPARATIVE STUDY OF TEACHING METHODS
IN THE SUBJECT OF CHEMISTRY**

Omprakash S. Chavan

PG Department of Chemistry,

Badrinarayan Barwale College,

Jalna-431213, Maharashtra, INDIA

(Affiliated to Dr. Babasaheb Ambedkar Marathwada University, Aurangabad)

Corresponding author E-mail: omprakashschavan@gmail.com

Abstract:

This article reports the findings of best experiment on teaching strategies in colleges and coaching classes which are typically practiced by the student teachers. In this study, I am giving attention towards different teaching methods commonly used by offline and online medium through teaching and learning styles in the classroom. Thus, the study had proposed that the respondents to change or modify or improve their teaching learning method while teaching experiment by applying the inquiry strategy and constructive approach.

Keyword: Teaching methods, Traditional approach, Modern approach, Teacher and student, Comparative study.

Introduction:

Chemistry is a most vital branch of science which deals with the study of chemical reaction, chemical structure, reaction mechanism, composition of matters and its different chemistry experiments. Now a day, rural as well as urban students are feeling this branch of science is slightly difficult due to the decrease in the interest of study of chemical science or increase in unlikeliness of the subject or not getting proper guidance for how to do the study or subject and others so many local reasons are found to decrease the knowledge of subject.

In the chemical Sciences and education, chemical experiments or practical as well as theories of chemistry are somewhat complex. [1] As the reactivity of substances as well as possible ways of producing a target molecule can at least partially be derived by the structures of the molecules, understanding the spatial structure of molecules has become more and more important. That is why chemists, chemistry students, who want to find out how they could produce a special or new substance without side reactions and products, that is important.

If you not understand the one route of study the we should go or try for another route for getting better method for understanding of teaching and learning. By this way you are getting more and more option to improve yourself in chemistry subject.

For structural clarification, there are several methods like UV Spectroscopy, NMR Spectroscopy, IR Spectroscopy, Electron microscopy or Mass spectrometry etc. In the subject of chemical education, many research paper and its report have been published for evaluation of teaching and learning methods.[2]

In the branch of chemistry, many more methods are used in teaching and learning process,[3] some of them are, direct teaching method in scientific language, [4] indirect teaching method, online teaching method, offline teaching method, by group discussion teaching method, teaching method by seminar presentation, teaching method by dissertation, teaching method by small project assignment, teaching by live demo method, teaching science by video games, [5] teaching by giving or explaining local and proper situation, teaching by giving house hold experiments, teaching method by surround situation in local language and so on.[6] [7]

In continuation of our interest, the current work represents the comparative study of different teaching methods in the chemical sciences and concluded that which is best method for teaching and learning process.

Teaching Methods:

In the study of different methods of teaching and learning process in the chemical science, found that, so many methods are presents or available in teaching learning process, they are as follows.

1. Hands on Teaching Learning method:

This is the best teaching method developed so far that includes the active involvement of students to understanding scientific ideas than to just have an audience view. Schools are helping the use of low price gadget in classrooms to helps students to have hands on culture experience.

2. Related Story Telling Teaching Learning method:

Students love to listen to stories and therefore, storytelling is one of the finest ways to get their consideration in class. Teacher can clarify the evidences of biology or the laws of physics in the form of stories. This is a cerebral organizer as human brains can think of stories than just pure facts.

3. Activities or Role Play Teaching Learning method:

This advanced method is becoming an fundamental part of science teaching as students can knowledgeable and physically involve through goings-on while learning a novel concept.

Activities can be prearranged in classroom meetings where a group of pupils can take the role of atoms or molecules to study a chemical response or they can characterize a scientist group to determine the particular scientist's laws.

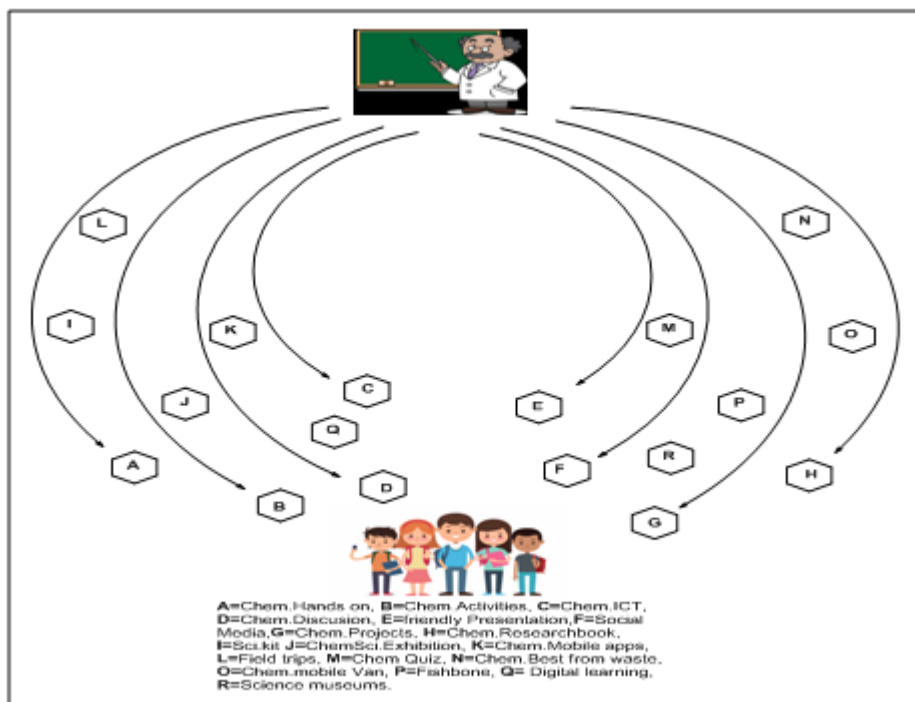

Figure 1: Factors to enhance teaching-learning process

4. Sports Based Teaching Learning method:

This is an stimulating approach to learn a stepwise technique to study compositecompound reactions.

5. Graphical clues Teaching Learning method:

Bygraphic clues definitely supplements acousticdata and students can wanting difficultyattach better with ideas.The multi-sensory documentations improve their accommodating and memorization. This embraces drawings, theclassification of lab techniques can be recovered taught using illustrations with words method.

6. Topic of discussion Teaching Learning method:

Building instructional conversations is a key method to teach science specially chemistry vocabulary. Let them exchange in between the speeches about the experience, they had with an presentation related to the subject of discussion. This stimulates their dialogue building in science as they transfer using scientific and mechanical terms. Make this a classroom policy to help students to without problems learn science terminology.

7. Chemistry Text Cards Teaching Learning method:

This is an ground-breaking teaching process to convey the science actualities in an easy and prearranged way. In this activity, statements related to science concepts are written on index

cards. Students can work on your own, pairs or in groups to sort the cards based on the given format. The formats include true/false, agree/disagree, matching pairs, classification, sequencing and more.

8. Graphic Organizers a Teaching Learning method:

This philosophy methodology is helpful for scholars to interact with knowledge in a more prearranged and arranged way. Teachers can use dissimilar types of patterns to represent the numbers according to the subject that is being pick up. A typical arrangement for graphic arranger contains a significant point from which dissimilar branches are designed and there may be subdivisions in certain circumstances. Arrows are castoff to point the path or structure of a procedure.

9. Word Parts Teaching Learning method:

This teaching policy is followed by professors to instruct the basics of science to fundamental students. Though introducing novel scientific relations, they can support the arrangement of words. Scholars are asked to classify and recognized prefix, suffix, and immoral word, and to narrate their meanings. For example, metamorphosis — large change, in process; photosynthesis — light make process.

10. Community mass media Teaching Learning method:

The diverse community media stands can be used sagaciously to teach discipline to make the science laboratories more stimulating and attractive. For instance, students can be asked to follow scientists in Twitter and share his/her new thoughts and findings in class or to use Feely for improving the content of their research. Scholars can also use Creeper to paper and to stake science videocassettes, Pinterest explanation for allocation images for investigation projects or scriptgoals or WordPress class account for peer-to-peer learning.

11. Cybernetic science labs Teaching Learning method:

About are many cybernetic science labs presented online for open and therefore, this methodology almost gives handsonpractice of learning the topic without abundant expense. Detailed maps, photographs or close up images allow scholars to practically get private a plant or animal part deprived of actually deed it. Like an experimentation a chemical response without injuries.

12. Chemistry Word walls a Teaching Learning method:

Chemistry term walls in laboratories can motivate the interest of pupils in the topic and anchance for them to demonstrate different concepts. In anprogressive technique, a extra in-depth appreciative of different scientific positions can be made probable with pictures that complement the words. This is similarly an option to assistance them better realize words with various meanings. Professors can design imaginative word walls or ask pupils to contribute to the hint weekly or monthly.

13. Mini anchor charts a Teaching Learning method:

These interesting charts are a great idea to give a detailed overview or explanation of a chemistry topic. Professors use it to interactively explain areas such as compound methods, types of dynamism, diff chemicalseries, states of material, combinations and solutions, force & signal and more. To mark the whole knowledge interesting, the professor brings differences such as dark and snowy charts, highlighted ones; fill in the complete models, and full-page announcer charts for large classrooms.

14. Crossover Teaching Learning method:

In this teaching method, pupils are given chance to learn in several settings such as private the classroom, galleries, field tours or clubs.

15. Context-Based Teaching Learning method:

In this method, pupils are given the chance to create situation and reconnoitre designs from them. They cooperate with surroundings, hold discussions with subject specialists, make significant notes and challenge to modify the neighbouring objects.

16. Computational thinking Teaching Learning method:

This is an innovative technique to expand thinking and difficult-solving skills. The technique involves freshness i.e. flouting large problems into minor units and pattern recognition-related complications to the ones which were previously solved successfully in the earlier. Computational thoughtful services also cover procedures-step by step methodology to reach answer.

17. Remote labs Teaching Learning method:

Knowledge by doing is an supreme approach to explain science and this is complete a reality with distant labs. Pupils are given access to dependable scientific apparatuses and chances to control inaccessible lab tests. This would enrich their inquiry abilities and conceptual empathetic and also, the pupils can learn and discover with inspiration.

18. By Science museums a Teaching Learning method:

Give chance to pupils to appointment a science gallery as part of the education method. This provides them admission to advanced resources and they can imagine data they learned in class. They can have a look at the real work of scientists which develops their need to learn about it further. Regular visits to museums make learning science more pleasing and remarkable.

19. By Projects work Teaching Learning method:

This can be an separate activity or cluster activity which advantages pupils to platform the submission side of what they academic through theory.

20. Multimedia Approach Teaching Learning method:

This technique is a combination of text, auditory, animatronics, video, quiet imageries or interactivity content methods to teach miscellaneous difficult to recognize ideas in science.

21. ICT Enabled Teaching Learning method:

ICT mentions to the use of Information and Communications Technology to communicate the scientific thoughts that encourages open source learning. In command to make the retrieving, storing, communicating, and management of information further easy, this methodology participates telecommunications, supercomputers and relevant initiative software, stowing, middleware, and cinematographic systems necessary to handle the topic.

22. By Video clips Teaching Learning method:

This coaching method makes use of instructional audio-visual clips accessible online or in public library to show and communicate a new idea. The progression of a process can be transported better with cartoon videos. It can also be videos of demo of an impression or an presentation side of a model or a talk with a scientist, tutorial by a subject expert and more.

23. Science Fair Schools a Teaching Learning method:

Knowledge carnivals as part of their teaching policy to encourage pupils interest in the topic as well as to calculate their level of accepting.

24. Teaching Learning method by Research books:

The professor can encourage the use of investigation records in classrooms fairly than just text files and lecture minutes. Pupils are asked to do an investigation on whatever subject is enclosed in class by means of books, websites or by chatting with experts. This can contain the stretched information of their curriculum and their findings with illustrations and diagrams to underscore it. They can portion their investigation books with colleagues too.

25. Documented Problem Solving Teaching Learning method:

The professor insists pupils record their alleged procedure when solving a difficulty. They are requested to explain their perceptive for realization the particular answer rather than simply presenting a solution. This kind of recognized problem resolving helps them to have a deeper empathetic of their procedure and gives an option for self-examination.

26. Teaching Learning method by Chemical Science kit:

This is one of the ground-breaking methods of teaching learning to children and grown person alike. Let it be corporeal science, natural life science, or earth science, professors are now building use of science supplies to help pupils have an attractive informative involvement.

27. Peer-to-Peer Teaching Learning method:

In this Teaching technique, Pupils take the role of training each other that encourages enjoyment learning science. In Peer-to-Peer Teaching methodology, they are really busy in the content by conferring scientific topics, producing questions and functioning in teams to discover new information.

28. Teaching Learning method showing Science movies:

Professors take advantages to take them for science cinemas in auditoriums or in school halls that plainly showcase the request side of scientific concepts. Supplementary than just charming them, many science cinemas captivate their devotion and demonstrate diverse science thoughts in the real domain. Science and nature-focused biographies is one of the best methods to introduce science to children than spoon serving them through text book content.

29. Teaching Learning method by Science games for kids:

Children always affection to play and that is why smart teachers announce science to them with exciting games. They can learn extra about science and knowledge with fun. A widespread range of sports are available wired that showcase the ideas of faunas, floras, space, marines, light, sounds, magnets, power, weather and vapours.

30. Teaching Learning method by Science songs:

This is additional creative teaching technique to help children to learn around the science domain with fun. Professors can make use of the remarkable science tunes available online or create one to announce the basics of stargazing, biology, chemistry, physical science and earth discipline with enjoyable.

31. Teaching Learning method visiting Science Exhibition:

Inspire your students to proceeds part in science demonstrations as part of school level or inter-school level competitions. This is a great opportunity to bring out their creativity in science and design an application based on a scientific concept. Develop this inquisitiveness and creative mind set in students correct from the straightforward classes to assistance them to grow up as science concepts.

32. Teaching Learning method by Chemistry Mobile apps:

For Knowledge a number of mobile apps are presented online for fundamental, middle school and high school pupils as well as for persons undergoing innovative studies. Today's children are tech understandings and they love to study science using their appliances.

33. Teaching Learning method by Field trips:

In the medium of unexciting classroom periods, take your pupils out for field trips to understanding science while knowledge. Go to an aquarium, a naturemiddle, a scientist's home or visit a domestic store. You can also apply some time with the pupils in the birdie park or basically go on aenvironment walk to skill the science around while learning new ideas.

34. Teaching Learning method by Science clubs:

Usual science bludgeons in your colleges or community, which is ansupreme approach to branch education that fit in high excellencepractical instruction. This is the correct place for science supporters to share and argue new activities in the science domain and to connect original ideas to what they truly learned.

35. Teaching Learning method by Interactive science journals:

This is an progressive version of speech notes in which pupils express the evidence they academic into altered patterns and stimulate their own responses. Pupils can use this method efficiently to have a bottomless connection to their education and this motion promotes their advanced level thoughtful. They can be imaginative with their notepads using images, diagrams, books and chemistry journals.

36. Teaching Learning method by Science at home:

Corresponding scientist say, science jumps from home-grown. Inspire your pupils to discover science at home-grown from fundamental lessons itself. Ask them to find ready a specific science idea claim at home as duties and let them determine science on the go.

37. Teaching Learning method by digital learning & flipped classroom:

In this inventive teaching performance, pupils are asked to go over audio-visual instructions or seminars in the preliminary stage, i.e. digital learning. The second phase will be in schoolrooms where they involve in inspiring tasks and homework based on the data gathered through audio-visual assets. This flipped learning delivers up class period for undertakings such as hands-on labs, channelled practice or online simulations.

38. Teaching Learning method by Fishbone:

This is a photographic tool for forming critical intellectual which is a good methodology for problem answering in science. The fishbone figure helps to teach pupils about the root grounds leading to a problematic and quantifying the association between the result and origin. This is more active when teaching an assembly. In this diagram methodology, the head of the fish represents the modification, the ribs indication the purpose and riblets have the helpful confirmation.

39. Teaching Learning method by Science Quiz:

Take in a quiz as a part of your schoolroom hearings when teaching science. The queries can include the presentation of the theory communicated in class. Students can argue and share thoughts to find the resolution within the required time structure. This teaching methodology helps pupils to think from dissimilar angles and occasionally, to think beyond the box.

40. Teaching Learning method by Best from waste:

Construct your classical this can be a stimulating task given to pupils as part of science teaching. Representations are the structure masses of science which are charity to expound the varied aspects of actual world. Ask your pupils to figure their own ideal using the scientific awareness they have developed and you can make available supportive management.

41. Teaching Learning method by Chemistry mobile van:

Systematically modified movable van is also play very significant role in the teaching learning technique. The chemistry mobile van expounded magic in understanding, what is afterjadu-tona, etc.

42. Teaching Learning method by Use Friendly Presentation:

Demonstration is the soul of the teaching method. The best way of attainmentpupils excited in chemistry is by bestowing it in aenergetic manner. Teachers may reinforcement the lectures with the mixture of panels and audio-visual aids such as OHP, PPT slides and videocassettes, etc.that varieties chemistry more successful and actual to the pupils.

43. Teaching Learning method by Correlate with everyday life:

Chemistry hints all aspects of our lives. Anpractisedteacher is able to attach the complexity of the science of chemistry with its each-day-life importance. There are trainings and recordsabout the daily life chemistry.

Some are straight forward teaching techniques are as follows.

a. Teaching Learning method by Lectures:

Chemistry talks are as communicating as possible, with considerations, question and answer and sessions, casual puzzles as well as the supplementary predictable lecture smartness. In most addresses you will be providing with hand-outs to review key points and arrangement your message taking.

b. Teaching Learning method by Workshops, Seminar :

Workspaces transform your information to appreciative. Working in lesser groups of nobles, you will discover problems and tie to material freshly covered in speeches. Workspaces allow you to study from each supplementary and gain sureness in your own abilities.

c. Teaching Learning method by Tutorials :

Seminars involve aassembly of six to eight pupils and one tutor. You will effort on problems in improvement of the tutorial and submit your graft for assessment. The lecturer then tailors each period to suit your developing data. You will have the chance to lead as well as underwrite to debates, and these sessions afford a forum at which you can present your ideas.

d. Teaching Learning method by Blackboard :

Blackboard is our fundamental learning atmosphere, where copies of address notes and other unusual teaching media like tapes and self-valuation tests are forwarded for you to admission to enhance your self-education.

e. Teaching Learning method by Laboratory work and practical sessions:

You will expend up to six hours a week in hands-on sessions, increasing your lab practise and demonstrating the theoretical ideas covered in speeches. These sessions are productiveness but genial, and allow you to obtain your own outcomes and generate subsidiary laboratory report.

f. Teaching Learning method by Self-study:

A vital part of university learning is self-study. You will be expected to dedicate a considerable amount of private study time each week to answering problem sheets, writing laboratory reports and reading around the different courses you will be taking.

g. Teaching Learning method by Personal tutor:

All new students are allocated a personal tutor immediately on arrival. This is a member of the academic staff in the Department of Chemistry who acts as a personal confidante during your time as an undergraduate. All our students are provided with a comprehensive set of materials and resources to ensure they get the most out of their degree.

h. Teaching Learning method by Problem Solving classes:

Like seminars, these typically complete around a series of problems. Nevertheless, in compare to lessons, the problem pages are solved by separating the class into minor clusters of students. Co-ordination makes these meetings an pleasant learning experience.

i. Teaching Learning method by Laboratory classes:

Chemistry is a very applied subject, and so durable emphasis is placed on the gaining of laboratory assistances. To help with your confidence, knowledge and appreciative of research laboratory practical's, you will have contact to a range of short instructional audio-visual clips that we have equipped in order to monitor you from side to side the investigational techniques before you go into the laboratory.

Result and Discussion:

In the process of teaching learning method, teacher should follow some basic ideas for teaching methods which becomes effective one, following point must refer,

Background of the Study:

Explanation of background talk is very important when teaching learning method is going on, suppose we are going to teach about 5 then ,we should talk about 3, then 4 then go to 5. Or first give some information about or teach about 7 then 6 then come on point 5.

Purpose of the Study:

What is main purpose of this teaching must be clear.

Research Hypotheses:

Before going to teach, you have some hypothecation about teaching topic in hand.

Effective Teaching:

If you know about background of topic, your purpose is very clear and you have some useful hypothecation in your hand, by using effective teaching method for understand to students then this will become your teaching effective.

Significance of the Study:

Explain some significance of study while effective teaching, this helps students for better understanding.

Demarcation of the Study:

Each training part has particular merits and disadvantages, but position merit and demerit in the form of proportional ways that is advantages to accepting very simply to the pupils.

Weaknesses in Teaching Methods Applied while Teaching:

- Argued the comfortable of investigate before students jump the experiment.
- Fixed high anticipation toward student's development in experiment.
- Pupils were providing with a set of well-equipped processes to follow.
- Highlighted on hypothetical ingredients like real book.
- Educator well-ordered the happenings of the pupils in term of experimentation, conversation and demonstration.
- Minimum participation of students in practical work.
- Minimum hands-on activities.
- Conducted lecture and discussion rather than actual experiment.
- Non-existence of inquiring or enquiry during the experimentation, demo and conversation of the statement and outcome data.
- Requested the students to finish the experiment as fast as possible.
- Time saving.
- Able to enhance students understanding toward the procedures in experiment.
- Easy to carry out approach.
- Common teaching method that had been used to it.
- Enable teacher to control and manage the class.
- High percentage of absentee of students.
- All will be well approach.

Teacher must have some characteristic point in them, for become good teacher.

- I found in this field is that being with young minds we always feel young and energetic.
- First of all you have to accept yourself as a teacher. What I mean is love your profession.
- Don't ever calculate your work in terms of money. Teaching should not become businesses. Salary issues should not be linked to quality of teaching.
- The relationship between a student and teacher should always be like a parent and a child (whatever may be the age gap). If you accept them like your children they too accept you like a parent and of course as a teacher.

- Try to remember the name of each and every student in the class because when you call them by names they feel closer and develop interest towards the subject and your teaching and approaches you freely to clarify their doubts.
- Many times children do mistakes or sometimes misbehave. Be very patient under those situations and try to talk to those students personally and counsel them with love. They definitely change (may not be immediately but slowly).
- Create your own style of teaching. Don't try to copy someone else's style. You can learn from your senior teachers of course but blend them in your own style and make an unique style of teaching.
- You can become a good teacher if your working style is meeting the expectations of the students and you can become a successful teacher when your working style is beyond the expectations (at least a little bit).
- Now coming to our subject it is a nightmare for many students due to vast syllabus and many reactions to remember. As a teacher we too have preferences either branchwise or chapterwise. Though we don't like some of the chapter/s but still we have to teach that chapter. Under those circumstances probably our psychology may help us. Initially we have to accept the situation and develop some liking towards the chapter and then to teach. (As I believe we do effective teaching when we like the chapter/ topic).
- Prepare for the class thoroughly and go to the class with a proper teaching plan of what to teach and to what depth you have to teach the topic. Time management is very important because in chemistry we have to give many connecting points. So you should have an idea to what extent those connecting points are to be taught.
- While preparing teaching plan for a class or for a day always give some cushioning time even for clarifying doubts (if any) raised by students in between the class.
- Don't ever argue while clarifying the doubts. If any particular student is not satisfied with the explanation what you gave then ask him/her to discuss it later after the class.
- To make the lesson interesting you can give examples from day to day life connecting to the topic.
- Give lot of tips and shortcuts to remember the concepts, equations, formulae, names of compounds etc. so that students feel the subject is easy.
- If you have to teach continuously for 2 to 3 hrs. give small breaks in between as a breathing time for children to digest the concepts which are already taught. Because listening to only one subject for such a long duration is difficult.
- Ask questions now and then just to make the class interactive.

- Conduct seminars on topics which require very less explanation by teacher because students remember the essence of the topic when they listen it from their friends or classmates (as a change). For example. Environmental chemistry of 11th class.
- If you are teaching for competitive exams it is better to give the knowledge about that particular topic how it was asked in previous year a competitive exam that gives a very good opinion on teacher.
- While solving Physical chemistry problems or organic sequential questions don't say the answers immediately. Let the student's struggle to get the answer by taking some time. Still if they don't get then try to explain in detail. Struggling make them perfect in the concepts.
- While teaching Inorganic chemistry instead of giving lengthy paragraphs as notes give the concepts in simple and short form as it is easy to remember and revise.
- For the reactions in inorganic chemistry students can guess the products based on the concepts for most of the reactions. And tell them not to worry about the reactions where their guess about products is correct. Then it is easy for them to practice the few reactions where their guess went wrong. This boosts the confidence to the students.
- Wherever it is required and if time permits better to show the reactions practically as it makes easy to remember the reactions. Here visual effects work very well.

Conclusion:

Authentic and practical learning environment provided in the laboratory work or experiment is a totally different scenario than the actual classroom learning environment and therefore it helps to motivate students to develop interest in learning the chemical reactions, reagents and basic concept of the same, with practical because through the experimental work, the students are able to develop the scientific skills. Discussion teaching method was found to be more effective than the normal teaching method.

In conclusion, here, reported that, comparative study of different teaching methods in the chemical sciences and it could be concluded that discussion teaching methods is a better instructional method for teaching chemistry and its adoption by chemistry teachers would go a long way in improving students' performance in chemistry.

Acknowledgements:

Author is thankful to the Principal, Badrinarayan Barwale College, Jalna for constant encouragement and providing necessary facilities for this work.

References:

1. Schmidt, A. L. (2011): "Creativity in science: Tensions between perception and practice," *Creative Education*, 2(5), 435.
2. Heikkinen, H. W. and J. S. Piquette, (2005): "Strategies for addressing alternative conceptions," *Journal of Research in Science Teaching*, 42(10), 1112-1134.
3. Fahmy, A.F.M., and Lagowski, J.J. (1999): The use of a systemic method in teaching and learning chemistry for the 21st century. *Pure Appl. Chem.*, 71(5), 859-863.
4. Bradley, J.D., and Moodie, P. (2017): The systemic approach to teaching and learning chemistry and the big ideas of science education. *AJCE*, 7(3), 45-56.
5. Smaldone, R. A. (2017): Teaching science through video games, *Nature Chemistry*, 9, 97-102.
6. Bradley, J.D., Khulu, S., Moodie, P., and Mphahlele, M. (2019): Using microscience kits to address a student-teacher misconception in electric circuits: at the interface between chemistry and electricity. *AJCE* 9(3), 37-45.
7. Chun Wu and Jordan Foos, (2010): Making Chemistry Fun to Learn, *Lit InfComputEduc J.*, 1(1): 3-7.

NANOTECHNOLOGY FOR WASTEWATER TREATMENT

Lekshmi R Babu* and Vidya KV

Department of Biotechnology and Biochemical Engineering,

Sree Buddha College of Engineering,

Pattoor, Kerala, India

*Corresponding author E-mail: bt.lekshmirb@sbccemail.in

Materials which have size smaller than 100 nm in at least one dimension are termed as Nanomaterials. At this scale, materials usually have new size-dependent properties changing from bigger counterparts; many applications have been explored in field of water and wastewater treatment. Many of these similar applications utilize the of nanomaterials which are very smooth and it is scalable in its size-dependent properties. It is usually related to the high specific surface area. It also depends on fast dissolution, high reactivity, and strong sorption. Various discontinuous properties, such as super paramagnetism and quantum confinement effect have been observed in the area of nanotechnology.

Adsorption

For removing various organic and inorganic contaminants in the field of water and wastewater treatment a polishing step is employed termed as adsorption. Normally in the conventional adsorbents surface area kinetics related to adsorption and selectivity is limited and efficiency plays a major role in it. To meet these limitations a new variety of nano-adsorbents which provide extremely high specific surface area shows significant improvement in their sorption sites, intraparticle diffusion distance is made short , size also becomes tunable.

Carbon based nano-adsorbents

The efficiency rate is higher for CNTs when compared with activated carbon. It strongly had association on adsorption of various organic chemicals. For the adsorption capacity to be in high mode it mainly depends on large specific surface area and the diverse contaminant which have interactions with carbon nano tubes. Usually adsorption is affected on individual CNTs mainly on their external surfaces, on surface area. When Carbon nano tubes are immersed in the aqueous phase it can form loose bundles/aggregates. The reason behind it is due to the hydrophobicity of their graphitic surface which in-turn reducing the effective surface area. The studies show that the aggregates of carbon nano tubes may contain interstitial spaces and

grooves. It will result in high adsorption energy sites which are required for organic molecules. When CNT bundles are used, it contains a significant number of micropores inaccessible to bulky organic molecules such as many antibiotics and pharmaceuticals. Thus the adsorption capacity of CNTs will be much for some bulky organic molecules. The reason behind is they have more pore size in their bundles and sorption sites are always more accessible. The drawback which was observed is adsorption capacity is very low. It is mainly due to their molecular weights in polar compounds.. CNTs have a tendency adsorb to usually observe polar organic compounds. It is due to the diverse contaminant CNT interactions including effects of hydrophobicity, hydrogen bonding, covalent bonding, and electrostatic interactions.

Many of the functional groups always try to form hydrogen bond with the graphitic CNT surface. It helps to donate electrons. The organic chemicals are positively charged and it maintains adsorption usually in some of the antibiotics at suitable pH and it is facilitated by electrostatic attraction.

Different types of Membranes and membrane processes

In any water treatment process ultimate goal is to make the treatment of water which is to remove undesired or polluted constituents from water. The basic technology adopted is membranes. They always act as a barrier of these type of contaminants. It is designed in such a manner that size is the factor which allows the particles to pass through the membrane. Even though in conventional mode membranes are used highest level of automations, less use of toxic chemicals and design flexibility should be ensured.

Selectivity and Permeability plays another role in these transport of materials through the membrane. But it is widely seen it as a major challenge of technology based on membrane. The next barrier observed in membrane driven process is use of high energy consumption in wide industrial applications. The major disadvantage of any membrane is fouling which adds the consumption of energy and thereby operations and design becomes more complicated. In some situations the lifetime of membranes and membrane modules can be reduced. In order to overcome the hurdles of membranes a new technology has been adopted which incorporates the functional nanomaterials into the membrane. It improves the permeability and resistance occurred due to fouling is overcome, stability due to mechanical and thermal effects are enhanced. It also renders new functions and abilities for enhancing the contaminant degradation and self-cleaning.

Nanocomposite membranes

Many studies showed that technique of membrane nanotechnology always creates a synergism and it results in the dys-functioning. The reason behind it is nanomaterials are

incorporated into polymeric or inorganic membranes. Nanomaterials used for such applications include hydrophilic metal oxide nanoparticles (e.g., Al₂O₃, TiO₂, and zeolite), antimicrobial nanoparticles (e.g., nano-Ag and CNTs), and (photo) catalytic nanomaterial.

The fouling needs to reduce by adding hydrophilic metal oxide nanoparticles into membranes. The addition of metal oxide nanoparticles and it is considered to be greatest goal. Including alumin, silica, zeolite and TiO₂ to polymeric ultrafiltration membranes has been shown to increase membrane surface hydrophilicity, water permeability, or fouling resistance. Some of the inorganic nanoparticles show significant effects on stability of polymeric membranes in mechanical and thermal aspects. It also reduces the negative impacts created on compaction in the permeability of membranes.

Membrane biofouling can be reduced to an extent by adding Antimicrobial nanomaterials which includes nano-Ag and CNTs etc Nano-Ag has been doped or surface grafted on polymeric membranes to inhibit bacterial attachment and biofilm formation on the membrane surface as well as inactivate viruses. But studies shows that long term efficacy is not observed . In practical aspects appropriate replenishment of nano-Ag needs to be addressed as a good technological initiative. CNTs inactivate bacteria upon direct contact. High bacterial inactivation (>90%) has been achieved using polyvinyl-N-carbazole-SWNT nanocomposite at 3 wt% of SWNT. CNTs are usually observed to be insoluble in nature and no need for replenishment is needed. There is a direct contact needed for inactivation. The experiments of long term filtration show the fouling impacts on antimicrobial activity of CNTs. The oxidized MWNT which has only 1.5 % by weight helps to enhance the permeability and hydrophilicity of polysulfone membranes.

In membranes Photocatalytic nanoparticle will be incorporated and it also combine their physical separation function and toward contaminant degradation is exhibited by reactivity of a catalyst. Much effort has been devoted to develop photocatalytic inorganic membranes consisting of nano-photocatalysts (normally nano-TiO₂ or modified nano-TiO₂). Metallic/bi-metallic catalyst nanoparticles such as nano zero-valent iron (nZVI) and noble metals supported on nZVI have been incorporated into polymeric membranes for reductive degradation of contaminants, particularly chlorinated compounds nZVI serves as the electron donor and the noble metals catalyze the reaction.

Biologically inspired membranes

The membranes which adopt biological procedures are seen to be very high selective and also it permeates the entry of materials. The observed aquaporins which act as a channel for protein always regulate water flux across cell membranes. The membrane performance is

improved mainly due to water permeability nature and high selectivity approach. This method is widely seen as attractive approach for the improvement in performance of membrane. Aquaporin-Z from *Escherichia coli* can be incorporated into vesicles made of amphiphilic triblock-polymer, It also exhibit less water permeability and an order of magnitude over the original vesicles is observed to be very less. It also shows the full length rejection to glucose, glycerol, salt, and urea. The design which is potentially observed is to coat aquaporin and finally incorporated into lipid bilayers on the membranes made of nanofiltration commercially. On this approach success was achieved in a limited manner,

One of CNTs named aligned CNTs exhibit experimentally and theoretically permeation capability of water and it is proved based on the Hagen Poiseuille equation, It predicts, the nano-sized channel have atomic smoothness and also there is an ordering of water molecules in one dimensional single-file when it is passing through the nanotubes. The predicted result of membranes are it contains only 0.03% surface area of aligned CNTs and flux will be exceeding the conventional RO membranes. In aligned CNTs sub nanometer diameter is lacking and due to this lacking there is a high of small molecules. Functional group which are present in the nanotube opening is now been proposed to enhance the selectivity of aligned CNT membranes.

References:

1. Konda reddy kunduru, michael nazarkovsky, Shady farah, Rajendra P. Pawar, Arijit basu, Abraham J. Domb; “Nanotechnology for water purification: applications of nanotechnology methods in wastewater treatment”; Austin chemical engineering.2016.25;235-238
2. Dharmendra K. Tiwari J. Behari and Prasenjit Sen, “Application of Nanoparticles in Waste Water Treatment”; World applied sciences journal. 2008; 3: 417-433.
3. Ilka gehrke, Andreas geiser, Annette somborn-schulz, “Innovations in nanotechnology for water treatment”, World applied sciences journal 2015.11; 112-115.
4. Samanta HS, Das R And Bhattachajee C, “Influence of Nanoparticles for Wastewater Treatment- A Short Review”; Austin Chemical Engineering, July 20, 2016.
5. Lizzy Mpenyana-Monyatsi, Nomcebo H. Mthombeni, Maurice S. Onyango and Maggy N.B. Momba, “Cost-Effective Filter Materials Coated with Silver Nanoparticles for the Removal of Pathogenic Bacteria in Groundwater”; Int. J. Environ. Res. Public Health 2012, 9, 244-271
6. Bottero, J.Y., Rose, J. And Wiesner, M.; “Rafael Castañeda Olvera , Sein León Silva, Eduardo Robles-belmont, Edgar Záyago Lau; ” Review of nanotechnology value chain

- for water treatment applications in Mexico”; *Resource-Efficient Technologies* 3 (2017) 1–11.
7. Bapusaheb B. Tambe Patil; “Wastewater Treatment Using Nanoparticles”; *Advanced Chemical Engineering*, 2015,5:3.
 8. Prashant Jain, T.Pradeep; “Potential of Silver Nanoparticle-Coated Polyurethane Foam As an Antibacterial Water Filter” *Wiley InterScience* 2015.
 9. Hiren D. Raval;“nanotechnology In Water Treatment:an Emerging Trend”; *Int. J. Nuclear Desalination*, Vol. 4, No. 2, 2010
 10. Tiwari DK, Behari J and Sen P. Application of Nanoparticles in Waste Water Treatment. *World Applied Sciences Journal*. 2008; 3: 417-433.
 11. Rafael Castañeda Olvera , Sein León Silva, Eduardo Robles-belmont, Edgar Záyago Lau; “Review of nanotechnology value chain for water treatment applications in Mexico”; *Resource-Efficient Technologies* 3 (2017) 1–11.
 12. Bhattacharya S, Saha I, Mukhopadhyay A, et al; “Role of nanotechnology in water treatment and purification: Potential applications and implications”; *International Journal of Chemical Science and Technology*. 2013; 3: 59-64.
 13. Nowack B; “Pollution prevention n treatment using Nanotechnology”; In *Environmental Aspects*. 2008
 14. Amin MT, Alazba AA, and Manzoor U;” A Review of Removal of Pollutantsfrom Water/Wastewater Using Different Types of Nanomaterials”; *Advances in Materials Science and Engineering*. 2014; 1-24
 15. C. Fishman, *The Big Thirst: “The Secret Life and Turbulent Futureof Water”*, Free Press, New York (2011).
 16. R. Helmer and I. Hespanhol, “Water Pollution Control: A Guide to the Use of Water Quality Management Principles”, E&FN Spon, London (2002).
 17. . G. L. Hornyak, J. Dutta, H. F. Tibbals, and A. K. Rao, “Introduction to Nanoscience”, CRC Press, Taylor & Francis Group, New York (2008).
 18. T. E. Cloete, M. De Kwaadsteniet, and M. Botes, “Nanotechnology in Water Treatment Applications”, *Caister Academic Press*, Poole,U. K. (2010).
 19. M. R. Templeton and P. D. Butler, “Introduction to Wastewater Treatment”, *Bookboon*, London (2011).
 20. F. S. G. Einschlag, *Waste Water Evaluation and Management*, InTech, Rijeka, Croatia (2011).

BIOFUEL FOR ENVIRONMENTAL SUSTAINABILITY IN INDIA: AN OVERVIEW

Kamala Mitra

Department of Chemistry,
Prasanta Chandra Mahalanobis Mahavidyalaya,
Kolkata 108. West Bengal, India

*Corresponding author E-mail: kmitrapcmm@gmail.com

Abstract:

Climate change has now become a major global problem, and a wide range of strategies are being used to address it. The International Energy Agency (IEA) recently advocated that carbon dioxide (CO₂) emissions be cut by 70% by 2060. CO₂ reductions in the transportation sector are critical to meeting this goal, since transportation accounts for around 23% of overall CO₂ emissions. Biofuels are one of the most effective methods for reducing CO₂ emissions in the transportation industry. *Jatropha curcas* (Jangli arandi) has a huge potential for biodiesel production in India since it grows abundantly in woods and wastelands. To enhance the production of biofuel from this feedstock, more study is needed. Bioethanol and biodiesel are the most common biofuels today. Biofuels account for a small percentage of global energy output. The National Biofuels Policy 2018 was adopted by our government. By 2022, the government wants 10% ethanol mixed gasoline, and by 2030, it wants 20%.

Keywords: Biofuels, Ethanol, Biodiesel, India.

Introduction:

Generation of Biofuels occur from renewable resources such as agricultural crops, woody and herbaceous biomass and waste materials which can be renewable annually or in several years. The major greenhouse gas (GHG) CO₂ is released from the combustion of biofuels which causes the global climate change. During the reproduction of renewable feedstocks for biofuels the CO₂ is utilized for biosynthesis.

Among the most promising alternative options Biofuels are considered most important, as they can be produced locally and to meet the transportation sector's requirements can be substituted for diesel and petrol. India, like many other countries, India is setting targets for the substitution of petroleum products by biofuels (Oh *et al.*, 2018). Since 2000, the Indian economy has grown at a rate of around 7% each year (EIA, 2013). To drive this high economic growth the

energy demand is also growing at rapid rates (Sinan, 2019). India's oil consumption would exceed 8 million barrels per day by 2035 (IEA, 2013), despite the fact that domestic crude oil output has been relatively stable throughout the years. The goal of this study is to learn about different types of Biofuels and and fate of it in future years. Thorough discussion has been done about the potentiality of Biofuel in India in this chapter.

Different Types of Biofuel:

According to the national policy on Biofuels 2018 defines the Biofuels as:

1) Bioethanol:

Ethanol produced from biomass such as sugar cane, sugar beet, sweet sorghum etc (Cheng and Timilsina, 2011), starch containing materials such as corn, cassava, rotten potatoes, algae etc. (Purohit and Chaturvedi, 2018), bagasse, wood waste, agriculture and forestry leftovers, or other renewable resources like as industrial waste (Nagi *et al.*, 2008) are examples of cellulosic materials.

2) Biodiesel:

Biodiesel is a fatty acid methyl or ethyl ester. These are produced from non-edible vegetable oils, acid oil, used animal fat or cooking oil.

3) Advanced Biofuels:

Fuels which are (i) produced from lingo-cellulosic feedstock's like agricultural and forestry residues, e.g woody biomass, non-food crops(i.e. grasses, algae), rice and wheat straw/corn cobs and stover/bagasse, or industrial waste and residue streams, (ii) having low CO₂ emission and do not compete with food crops for land use. Fuels such as Second Generation (2G) Ethanol, algae based 3G biofuels, bio-CNG, bio-methanol, Di Methyl Ether (DME) derived from bio-methanol, bio-hydrogen, Drop-in fuels with municipal solid wastes as the feedstock material will qualify as "Advanced Biofuels".

Different Process for Biofuel Production

Different process for production of Bio Ethanol:

- a) Yeast is used to ferment the starch in corn, sugar cane, and sugar beets. Now a day's Ethanol is manufactured by this most common fermentation process. Sugar cane and sugar beets are the most common feedstock's used to make fuel ethanol.
- b) Cellulosic materials, which provide structure to plants, comprise the stems, stalks, and leaves of plants as well as trunks of trees. Cellulosic materials, which include cellulose and

hemicellulose, may be broken down into sugars, which may then be fermented to produce ethanol. Cellulosic materials being studied for the production of biofuels includes those found in switchgrass, prairie grasses, cornhusks, wood chips, forestry materials and residues as well as other inedible agricultural plant waste. These cellulosic materials produce the ethanol which is referred to as cellulosic ethanol.

Production of biodiesel is carried out by trans-esterification and esterification of vegetable or animal fats and oils using methanol or ethanol. Triglycerides of animal and plant in the presence of a catalyst (acid and/or base) are submitted to a transesterification process under heat. The majority of biodiesel is made from virgin vegetable oils; this is a more economical process as low temperatures and pressures give rise to yield of conversion about 98% (Pavlenko *et al.*, 2019).

Hydrotreated Vegetable Oils (HVO), Hydroprocessed Esters and Fatty Acids (HEFA), Cellulosic ethanol, BioSynthetic Natural Gas (BioSNG), Biomass to Liquid (BtL) is generally produced via gasification. Methanol is now generated mostly by catalytic syngas conversion (a mix of carbon monoxide, carbon dioxide and hydrogen) (Hoekmana *et al.*, 2012). Methanol can be catalytically dehydrated to yield BioDME (dimethylether). Biobutanol is commonly utilised as a transportation fuel. Synthetic paraffinic fuel can be produced via chemical catalysis of plant sugars (Purohit and Fischer, 2014). Hydrogen can potentially be produced from biomass and can be used as a vehicle fuel is called Biohydrogen. Macro algae (seaweeds) and microalgae can be used for the production of Algal biofuels (Ho *et al.*, 2014).

Discussion:

Production of Biofuels occur in many countries from first-generation food based feedstocks such as corn, soybeans, or palm oil, Generally valuable croplands are occupied by these feedstocks. Meanwhile, India has identified other sources for advanced biofuels; such as by-products, domestically available wastes, and residues that can be used for energy without disturbing food markets. Generally non-food crops grown on marginal lands are called Energy crops. These are the potential significant source of low carbon biofuel in India, and they have low ILUC emissions (Roddy, 2012).

Malaysia utilizes palm oil while *Jatropha curcas* (The Physic Nut) was used by Nicaragua for bio diesel production. Because *Jatropha curcas* grows abundantly in India's woods and wastelands, it has a huge potential for biodiesel production (Purohit and Dhar, 2015). National Biodiesel Mission (NBM) was launched by the Union government in December 2009,

identifying *Jatropha* as the most suitable tree-borne oil seed for biodiesel production. It was proposed that biodiesel blend of 20 per cent with conventional diesel can be achieved by 2017.

Biodiesel procurement started in 2014 with a pilot program in August 2015. It has since been expanded to include six additional states. However, acute shortage of *Jatropha* seeds was the barrier for, the government's ambitious plan to materialize. To mitigate the issue multiple feedstock technology were adopted by several existing biodiesel plants to shift their operations (Beguin and Aubert, 1994).

India generates vast quantities of Used cooking Oil which are not properly used in Restaurants and Food industries. Food Safety and Standards Authority (FSSAI) estimate in 2018 that 23 million tonnes of cooking oil is consumed annually in India. Out of this 30%, is improperly disposed of and thus available for biofuel production. According to FSSAI's assumption roughly 3.1 million tonnes of used cooking oil would be available in 2030 for Biodiesel production. A Committee was constituted in July 2002 by the Planning Commission of India for the Development of Biofuels (Kim and Dale, 2004).

20 States and 8 Union Territories were mandated for 5% blending in 2006. In 2008 5% target was set by the union cabinet due to shortage of supply. National Mission on Biodiesel was recommended to launch by the Planning commission to raise the target by 20% within the year 2012. The Government of India announced a National Biofuel Policy in December 2009 to address the deficiency in this blending scheme. India now has six biodiesel facilities with a total yearly capacity of 650 million liters.

The data of production of Biodiesel annually is shown in the Table 1. Biodiesel Production in India from Multiple Feedstocks (Million Liters)

Table 1: Biodiesel Production in India from Multiple Feedstocks (Million Liters)

Calendar Year	Biodiesel (Million Liters)									
	2010	2011	2012	2013	2014	2015	2016	2017	2018	2019
Beginning Stocks	45	15	13	14	15	11	13	13	18	25
Production	100	111	126	132	138	152	158	170	185	190
Imports	0.0	0.0	0.0	0.3	1.7	0.8	2.7	7.1	25.2	11.5
Exports	0	0	0	3.9	41.5	33.1	41.7	7.6	23.1	19.7
Consumption	131	113	125	128	102	118	119	165	180	185
Ending Stocks	15	13	14	15	11	13	13	18	25	22

(Source India Biofuels Annual 2019, GAIN Report Number: IN9069. Date: 8/2/2019.)

It is estimated that the market of ethanol in India is projected to grow from \$2.50 billion in 2018 to \$ 7.38 billion by 2024. Another report by the International Energy Agency says the Indian biofuel market is forecasted to grow 11% from 2019 to 2024. The rate of ethanol blending is increasing as the government pushes for higher blending through deregulation of feedstocks, soft loans for increased investment in ethanol production, and an emphasis on 2G ethanol technology and commercialization. Sugarcane output is predicted to grow again in the 2020-21 season, with ethanol manufacturing capacity in the country likely to expand by 375-400 crore litres. As a result, the goal ethanol blending rate of 7.5-8 percent is likely to be met in 2020-21

Conclusion:

Under the new 2018 biofuels policy expansion of the fuel ethanol industry are strong. Financial health of sugar mills will be supported by the increased fuel ethanol production while also displacing the demand of higher share of gasoline. Biodiesel and hydrotreated vegetable oil production from used cooking oil feedstock offers promise. To avoid negative health impacts framework for the encouragement for not to reuse of cooking oil and its collection to produce biodiesel or hydrotreated vegetable oil should be initiated.

Support for the emerging advanced biofuels industry is also commendable due to the high availability of agricultural residues. This development can support various programme; increasing farmers' income; reducing energy imports and therefore meeting the goal to reduce crude oil imports by 10% by 2022; and supporting waste to wealth creation.

References

1. Oh You-Kwan, Hwang Kyung-Ran, Kim Changman, Kim Jung Rae, Lee Jin-Suk (2018): Recent developments and key barriers to advanced biofuels: A short review, *Bioresource Technology*, 257, 320–333.
2. Sinan, Mominul (2019): Biofuels and Recent Development in India: A Review, *International Journal of Scientific Research and Reviews*, 8(1), 3249-3258.
3. Cheng Jay J. and Timilsina Govinda R. (2011) Status and Barriers of Advanced Biofuel Technologies: A Review. *Renewable Energy*, 36, 3541-3549.
4. Purohit Pallav and Chaturvedi Vaibhav (2018): Biomass pellets for power generation in India: a techno-economic evaluation, *Environmental Science and Pollution Research*, 25(1), 29614–29632.
5. Nagi Jawad, Ahmed Syed Khaleel, Nagi Farrukh (2008): Palm Biodiesel an Alternative Green Renewable Energy for the Energy Demands of the Future, *ICCBT, F (07)*, 79-94.

6. Pavlenko Nikita, Searle Stephanie and Christensen Adam (2019): The cost of supporting alternative jet fuels in the European Union, International Council on Clean Transportation (ICCT), Washington DC, USA 1-20.
7. Hoekmana Kent, Brocha Amber, Robbins Curtis, Cenicerros Eric, Natarajan Mani (2012): Review of Biodiesel Composition, Properties and Specifications Renewable and Sustainable Energy Reviews, 16, 143– 169.
8. Purohit Pallav, Fischer DI Günther, (2014), Promoting low carbon transport in India Second Generation Biofuel Potential in India: Sustainability and Cost Considerations, Magnum Custom Publishing New Delhi, India, 9.
9. P Ho Dang, Ngo Huu Hao, Guo Wenshan (2014): A mini review on renewable sources for biofuel, Bioresource Technology, 169, 742–749.
10. Roddy, Dermot J (2012): Biomass and Biofuels – Introduction ,Comprehensive Renewable Energy, Elsevier, Hoboken, 5, 1-9.
11. Purohit Pallav and Dhar Subhas (2015): Biofuel Roadmap for India, UNEP DTU Partnership.
12. Pierre Beguin and Aubert Jean-Paul (1994) The biological degradation of cellulose FEMS Microbiology Reviews, 13, 25-58.
13. Kimand Seungdo and Dale Bruce E (2004): Global potential bioethanol production from wasred crops andd crop residues, Biomass and Bioenergy, 26(4), 361-375.

USE OF WASTE EGGSHELL MEMBRANE IN PREPARATION OF LITHIUM-ION BATTERIES

Sonia Deswal¹ and Narayan D. Totewad^{2*}

¹Department of Physics,
Malaviya National Institute of Technology, Jaipur, India

²Department of Microbiology,
B. K. Birla College of Arts, Science and Commerce (Autonomous),
Kalyan-421304, Maharashtra, India

*Corresponding author E-mail: ndtmicro2013@gmail.com

Abstract:

The common birds egg content as yolk and white has been used by human being as a source of food from very long time but now, we can use another important component of eggs as Eggshell membrane (ESM). But the shell is typically discarded, and this means a lot of eggshell waste. The dumping of eggshell waste is an ecologically and economically challenging problem. This chapter provides basic information about ESM starting with its structure, Separation of the Egg Shell Membrane and Material Synthesis, and its properties. Chicken egg membrane (CEM) shows better discharging ability and very low impedance. BET means Brunauer–Emmett–Teller analysis used to determine eggshell membrane surface area, give electrochemical cycling stability of the lithium metal batteries. There are various fabrication methods and synthesizing process, in this chapter, touches upon Major Synthesized method is the sol-gel method, nanomaterial synthesis template, using a different aqueous solution. Finally, we lay down the framework to explain the importance of eggshell membrane in multiple ways as applications in engineering as electrical devices- Batteries, capacitor -oxygen evolution reaction catalysis, solar cells- counter electrode and fuel cells-anodes, cathode, electrode sensors. ESMs adsorption properties provide the ESMs applications in bio-template, bio-sorbent, biosensor or medicine, and material science, environmental engineering, biomedical engineering, and commercialization.

Keywords: Egg Shell, BET, Lithium-ion, Electrode Sensor, Nanoparticles

Introduction:

On large scale availability of Eggshell (ES), eggshell membrane (ESM) and egg wastes are the results of the worldwide use of hen eggs in quite large quantities. The main

problem in poultry farms, food industry and bakery are, how to dispose eggshell and eggshell membrane. Fertilizer and dietary supplements are the recycle of eggshells but there is more way to use of eggshells but the problem is that separation of eggshell from egg. The most interesting benefit of eggshells recycling for making battery electrodes is that no separation of two parts, since both parts are used together, here ESM is used as multifunctional reactors. So, there is investigation of use of eggshell membrane for the preparation of batteries from Lithium-ion, this application is the interdisciplinary approach for sustainable use of resources.

The wide spectrum of the applications of the ESM, which are more efficient when the ESM synthesis process is done without any impurities and disorder, a different type of characteristic technique is used for the information of composition and surface fractures, image morphology, topography, crystallography of ESMs. ESMs have many unique characteristics, and it is a promising bioresource. However, there are still limitations and restrictions. So, there is need to understand properties of eggshell membrane because small alteration in the structure may affect chemical and mechanical properties of eggshell membrane. Other than engineering eggshell membrane have various applications in biological and agriculture sector, biomedical field.

Eggshell Membrane (ESM)

Two membranes lie directly beneath the shell, and these are suitably called inner and outer shell membranes. Shells mammillary layer shadowed by the outer shell membrane and liquid of the eggs around the inner shell membrane. There is separation of two membranes at bigger end of the eggs which create a small space between them known as 'Air Cell'. When an egg is laid by the bird then after the process of contraction and cooling, the air cell is molded in the egg. The ESM is a clear thin film coating the ES. ESM is visible on peeling the boiled egg (Mittal *et al.*, 2016).

ESM has good adsorption properties which come from the formation characteristic, ESM holds a porous and fibril creation a complex lattice of stable and water-insoluble fibers, these fibers are the amorphous natural biomaterial. ESM is a light pink double-layered membrane. These double-layered membranes are composed of protein fiber and the complete thickness of these membranes is approximately 100 μm . These ESM double-layered membranes settled to form

Thermochemical conversion of eggshell as biological waste and its application as a functional material for the preparation of lithium-ion batteries. The chicken eggshell membrane has the best

electrochemical performance with the greatest discharging capacity, smallest impedance.

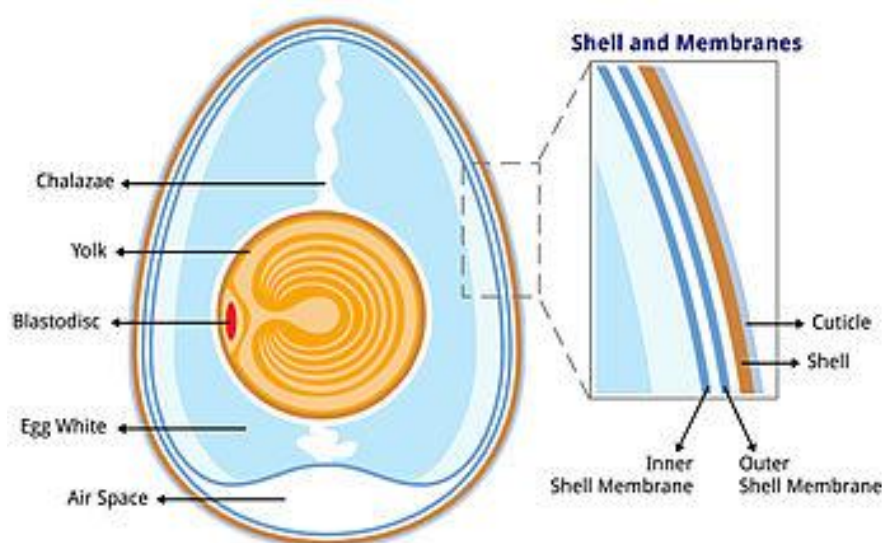

Figure 1: Eggshell membranes (Source: Ishikawa and Suyama, 2020)

The advanced battery market covering the three main application segments: portable electronics, electric mobility, stationary energy storage a semi-permeable membrane.

Separation of the Egg Shell Membrane and Material Synthesis

In a typical procedure, both eggshell and its eggshell membrane along with eggshell waste were obtained from fresh eggs purchased from a nearby grocery store by pulling out the liquid content of yolk and white through a hole cut in the eggshell. The eggshell waste was washed with deionized water. The name of Eggshell membrane given on the basis of name of birds eggshell membrane as like chickens (Chicken eggshell membrane), Quails (Quail Eggshell Membrane) and Goose (Goose Eggshell Membrane). All eggshell membranes are made up of protein fibers. If we measure surface area and thickness of various eggshell membranes using BET analysis as CEM ($3.33 \text{ m}^2 \text{ g}^{-1}$; $95 \mu\text{m}$), QEM ($6.22 \text{ m}^2 \text{ g}^{-1}$; $52 \mu\text{m}$) and Goose eggshell membrane (GEM) is ($5.92 \text{ m}^2 \text{ g}^{-1}$; $129 \mu\text{m}$) respectively. Chicken eggshell membrane surface area is smaller, uniformed, and well distributed which prevents dendritic lithium on the surface. There is low internal resistance to thin separators and possess high energy and power density which affects negatively on mechanical strength and safety. Improvement in safety of battery cause due to battery assembly and thicker separators give maximum mechanical strength. The good electrochemical ability with high discharging capacity, with lower impedance and higher diffusion coefficient of lithium-ion. The Chicken eggshell membrane sample shows good electrochemical performance with smallest surface area of $3.33 \text{ m}^2 \text{ g}^{-1}$.

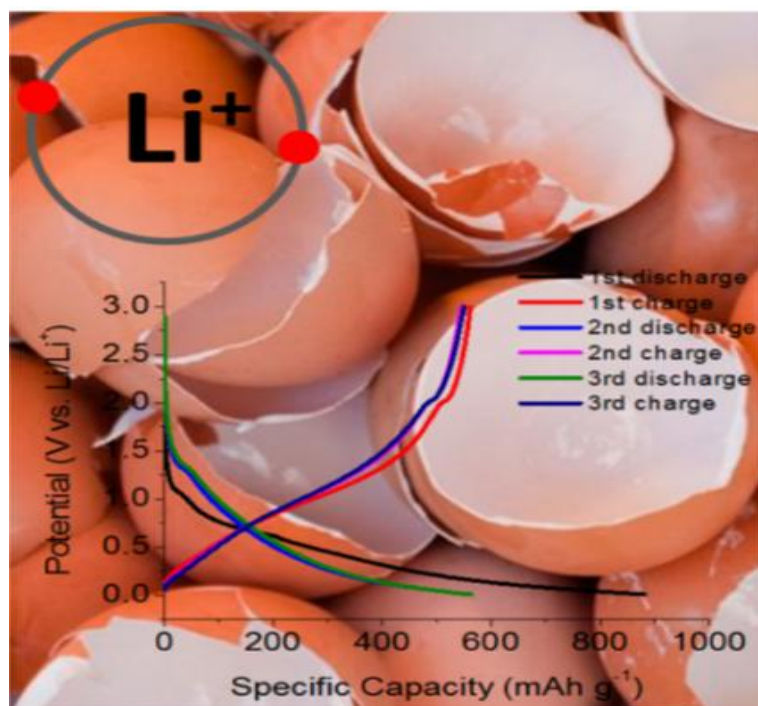

Figure 2: Chicken Eggshell membrane composition (Source: Meng and Deng, 2016)

The lithium-ion battery assembled with chicken eggshell membrane shows lithium ion diffusion coefficient as $1.25 \times 10^{-14} \text{ cm}^2 \text{ s}^{-1}$, and the discharge capacity of 90 and 87 mAh g^{-1} at 1st, and 150 the cycle at the current density of 0.5 mA cm^{-2} , respectively. Therefore, it was pointed out that recycled natural ESMs are promising alternative materials for separators (Nguyen *et al.*, 2018).

Separation of RESM

Annually, over 10^{12} eggs are consumed worldwide, thereby leading to an increase in waste from eggs. Egg by-products have generally been overlooked and disposed of as waste. Calcium and Phosphate present in hard Eggshell (ES). For the experiment purchased fresh eggs from supermarket. Eggs were broken down and made empty and then used deionized water to wash eggshells and inner shell membrane. Later, manually separate eggshell into limiting and inner shell membrane. The remaining eggshells were rinsed in 1M HCl to dissolve the CaCO_3 , leaving the organic outer shell membrane. Use water for cleaning of outer shell membrane thoroughly and it was After the outer shell membrane was cleaned with water thoroughly and was further purified by 2-propanol to pull out the microorganism from the fine pores of the membrane (Yi *et al.*, 2004).

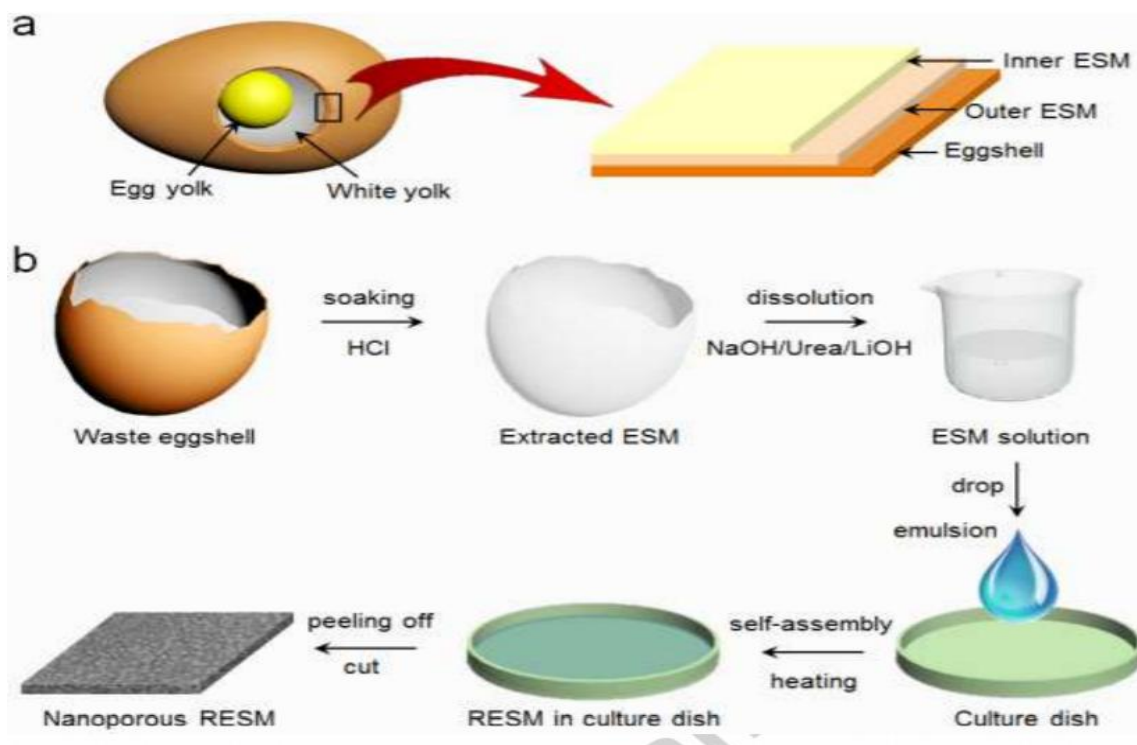

Figure: 3 Cycles for the nanoporous RESM (Ma et.al. 2018)

Figure 3(a) Structural diagrams of egg and eggshell. Figure 1 (b) RESM preparation process

Eggshell membrane and flat regenerated ESM (RESM) films consist of functional groups of nitrogen with maximum polarity and lipophilicity which leads to maximum strong affinity with Li^+ and limited suppression of Li dendrite growth. The RESM well well-maintained the original flexible structure of raw ESM. Better to the micro-scale pores of the Celgard separator, the nano-scale porosity of ESM and RESM can greatly overpower the growth of large-sized lithium dendrites. ESM is being examined for the development of batteries as a replacement for lithium-ion. To store energy Carbonized Eggshell membrane-based platform used and battery anode consist of fibrous network with uniformly arranged microporous structure, larger surface area, high volumetric energy density, high capacity, stability, and increased volumetric energy density suitable for applications in Industry. One of the best example is LieS battery was developed by researcher Chung and Manthiram who used polysulfide sorbent as carbonized ESM. Diffusion of dissolved polysulfide occur through the separator and then it reacts with anode of Lithium, resulting in increase in discharge capacity, severe sulfur loading and get long-term cycle stability (Ma *et al.*, 2018).

For the supercapacitor application, a separator is equipped based on the natural and stretchy eggshell membrane (ESM). Morphology remark shows that the ESM involves a

hierarchically methodical macroporous network. For supercapacitor separators, ESM could be a hopeful contender.

ESM-based platforms:

ESM can be utilized in different forms as A to E given in the figure (4):

(A) Generally, there is physical separation of eggshell from eggshell membrane and dipping of eggshell membrane into solution of hydrogen chloride for total removal of remaining eggshell and dried at room temperature, in this way separation and preparation of Eggshell membrane.

(B) Eggshell membrane is carbonized on grassy carbon discs in presence of Argon at 800 °C and then it is activated at 30 °C in the air so electric properties are enhanced, this whole process is called as Carbonization of Eggshell membrane (Suyama *et al.*, 1994).

(C) Further immobilization of chemical components was carried out on Eggshell membrane and enhance electroconductivity of eggshell membrane.

(D) Then Eggshell membrane used as template for the formation of interwoven structures by presence of available metal ions.

(E) Eggshell membrane is insoluble in water so to obtain its soluble protein it is treated with specific acidic solution (Liang *et al.*, 2014).

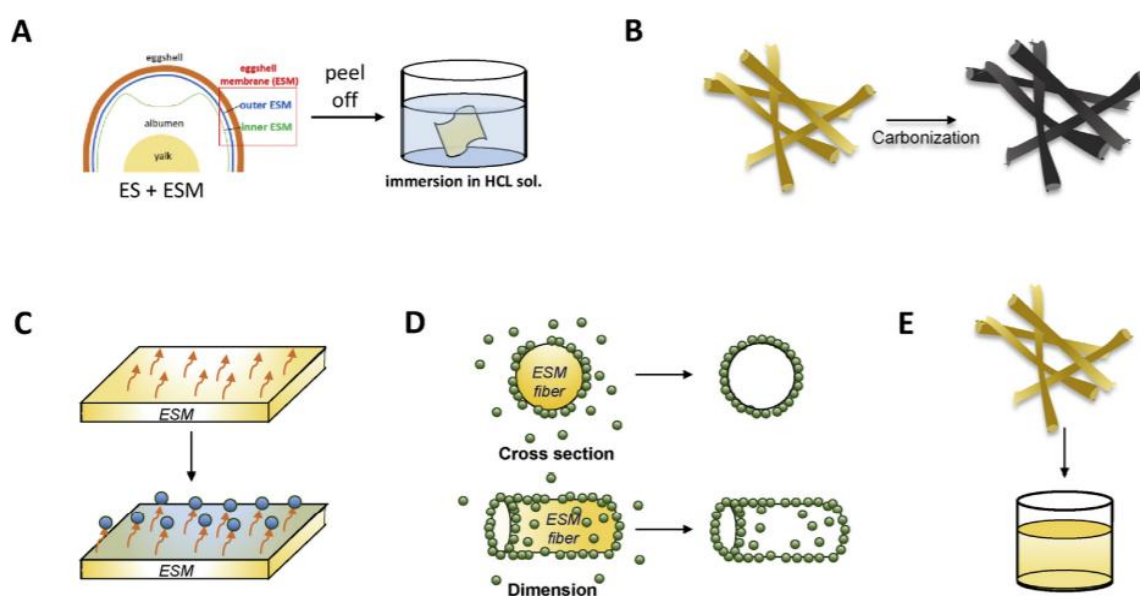

Figure 4: ESM has been utilized in various forms (Source: Liang *et al.*, 2014)

BET Analysis

BET analysis applies to multilayer adsorption system uses gases which are not going to react with surface of material to measure quantitatively specific surface area. BET gives information about adsorption of gas molecules physically on solid surface and it can be used for measurement of specific surface area of various materials. e.g. Gas adsorption or Nitrogen adsorption. The researcher Stephen Brunauer, Paul Hugh Emmett, and Edward Teller directly measured surface area and distribution of pore size. Nitrogen is one of the most common gaseous adsorbates used for surface probing by BET analysis methods. Due to this reason BET analysis maximally conducted at boiling temperature of Nitrogen. Examples of some probing adsorbates are carbon dioxide, argon and water. BET analysis in estimating the surface areas of ESMS, give electrochemical cycling stability of the lithium metal batteries (Park *et al.*, 2016)

Applications of Egg Shell Membrane

1. Eggshell membrane can be used in preparation of electrical devices with some features as low resistance, ability to charge and discharge quickly and excellent cycling stability due to its porosity and decomposition ability at greater than 200 °C, swelling at low degree and good mechanical strength (Yang *et al.*, 2010).
2. Eggshell membrane can be used in Capacitors due to rapid charged or discharged ability due to longer life cycle and high-power density and mainly used in portable devices (Yu *et al.*, 2012).
3. Solar cells can be manufactured from Eggshell membrane are inexpensive, non-toxic to use as compare with other materials and allow formation of crystalline and I-/I³⁻- redox in the light to the electricity conversion process (Wang *et al.*, 2015).
4. **Semiconductors and fuel cells:** Application of nanoparticles, structure and shape determines the efficiency of semiconductors. Semiconductor can be developed by using various materials like lead (Pb), sulfide (S) and nanocrystalline PbS belongs to the IV-VI semiconductor group. Also, Eggshell membrane is used as template in fuel cell manufacturing and production development. Various components of eggshell membrane (glycoprotein matrices, collagenous cores, uronic acids, sialic acids, and several amino acids) allow metal ions to form well-ordered structures. Particularly-COO⁻ and the -NH₃⁺ charge mainly contribute to networks in collagen and glycoproteins. Eggshell membrane-based fuel cells have low polarization resistance and activation energy than conventional materials used. So, therefore, Eggshell membrane SM is highly appropriate for solid oxide fuel cell anodes preparation (Flores-Acosta *et al.*, 2003).

5. Eggshell membrane is also suitable for sensor fabrication which gives good results and high efficiency.
6. Use of eggshell membrane in the detection of DNA, horseradish peroxidase, glucose (Dong *et al.*, 2007).
7. Eggshell membrane we can use in Biomedical engineering as biomaterial due to its low toxicity and biocompatibility.
8. Use in the modification of the template, synthesis, and rawmaterial preparation (Yi *et al.*, 2004).
9. Modification of Synthesis which is the combination of Polysaccharide/Protein microcapsules, Phosphate groups PEO, PVA, and Catechin used in biomedical in the delivery system, in wound dressing and for Type I collagen mineralization.
10. Modification of the Template as Calcium phosphate or Silica has application so, Diatom cells can be used in biomedical for Calcification and Silicification (Yang *et al.*, 2010).
11. ESM has been adapted to nanoparticles and used as an adsorptive material, use of nanostructured material from Eggshell, removal of cadmium and lead ions from wastewater and other applications such as bio-template in the synthesis process of nanoparticles, or biosensor, or membrane between 2 parts of the electrolyte in a supercapacitor used.

References:

1. Mittal A, Teotia M, Soni RK and Mittal J. (2016). Applications of eggshell and eggshell membranes as adsorbents: A review, *J Mol Liq*, 223:376–87. <http://dx.doi.org/10.1016/j.molliq.2016.08.065>
2. Ishikawa S and Suyama K (1998). Recovery and Refining of Au by Gold-Cyanide Ion Biosorption Using Animal Fibrous Proteins. In: *Biotechnology for Fuels and Chemicals*. Humana Press, 719–28. https://link.springer.com/chapter/10.1007/978-1-4612-1814-2_66
3. Meng X and Deng D. (2016). Trash to Treasure: Waste Eggshells Used as Reactor and Template for Synthesis of Co₉S₈ Nanorod Arrays on Carbon Fibers for Energy Storage, *Chem Mater.*, 28 (11) :3897–904.
4. Nguyen V. H., Lee D. H., Baek S. Y. and Kim Y. H (2018). Recycling different eggshell membranes for lithium-ion battery, *Mater Lett.* 228:504–8. <https://doi.org/10.1016/j.matlet.2018.06.081>
5. Yi F, Guo ZX, Zhang LX, Yu J and Li Q (2004). Soluble eggshell membrane protein: Preparation, characterization and biocompatibility, *Biomaterials*. 25(19):4591–9.

6. Ma L, Chen R, Hu Y, Zhang W, Zhu G and Zhao P (2018). Nanoporous and lyophilic battery separator from regenerated eggshell membrane with effective suppression of dendritic lithium growth, *Energy Storage Mater.*, 14:258–66.
7. Suyama K, Fukazawa Y and Umetsu Y. (1994). A new biomaterial, hen eggshell membrane, to eliminate heavy metal ion from their dilute waste solution, *ApplBiochemBiotechnol.*, 45–46 (1):871–9.
8. Liang M, Su R, Qi W, Zhang Y, Huang R and Yu Y. (2014). Reduction of Hexavalent chromium using recyclable Pt/Pd nanoparticles immobilized on procyanidin-grafted eggshell membrane, *Ind Eng Chem Res.*, 53(35):13635–43.
9. Park S, Choi K. S., Lee D, Kim D, Lim K.T. and Lee K.H. (2016). Eggshell membrane: Review and impact on engineering. *BiosystEng.*,151:446–63. <http://dx.doi.org/10.1016/j.biosystemseng.2016.10.014>
10. Yang Z, Peng H, Wang W and Liu T. (2010). Crystallization behavior of poly(ϵ -caprolactone)/layered double hydroxide nanocomposites. *J Appl Polym Sci.*, 116(5):2658–67.
11. Yu H, Tang Q, Wu J, Lin Y, Fan L and Huang M. (2012). Using eggshell membrane as a separator in supercapacitor, *J Power Sources.*, 206:463–8. <http://dx.doi.org/10.1016/j.jpowsour.2012.01.116>
12. Wang A, Bai Y, Gao H, Wang S. (2015). A tetracycline-selective fluorescent biosensor using anthranilic acid immobilized on a glutaraldehyde-coated eggshell membrane, *Anal Methods.*, 7(16):6842–7.
13. Flores-Acosta M, Sotelo-Lerma M, Arizpe-Chávez H, Castellón-Barraza FF and Ramírez-Bon R. (2003). Excitonic absorption of spherical PbS nanoparticles in zeolite A. *Solid State Commun.*, 128(11):407–11.
14. Dong Q, Su H, Xu J, Zhang D and Wang R. (2007). Synthesis of biomorphic ZnO interwoven microfibers using eggshell membrane as the biotemplate, *Mater Lett.* 61(13):27147.

RECENT APPLICATIONS AND DEVELOPMENTS OF NANOTECHNOLOGY IN NANOMEDICINE

Shalmali Hui

Department of Chemistry,

Hijli College (Affiliated to Vidyasagar University),

Kharagpur, West Bengal, India

Corresponding author E-mail: mamoni06@gmail.com

Abstract:

Nowadays the field of nanoscience and nanotechnology has potential advantages in various disciplines of science. During the last three decades nanomaterials play a significant role to advance nanotechnology strategies because of their novel and fascinating properties. The extensive use of some of the nanoscale materials for clinical applications leads to emerge a new area – nanomedicine. It is an interdisciplinary field that combines biology, chemistry, engineering and medicine. The use of nanoscale materials in several biomedical fields has a promising potential for prevention, diagnosis and treatment of several diseases. This article presents a comprehensive framework of the recent exciting applications and developments of nanotechnology in nanomedicine with special emphasis given on carbon nanotubes till date.

Keywords: Nanotechnology; Carbon nanotubes; Nanomedicine; Biomedical applications; Photodynamic and photothermal therapy; Drug/gene delivery

Introduction:

Nanotechnology is a multidisciplinary field of research and innovation that deals with materials at the atomic and molecular levels. It has a significant potential in various disciplines of science such as, chemistry, biology, physics, materials science, engineering etc. During the past three decades nanoscale materials (size range: 1-100 nm) like nanorods, nanowires, nanotubes, nanobelts, nanoribbons, nanofibers, nanoparticles, quantum dots, and hollow spheres are extensively used to upgrade the strategies of nanotechnology. In recent years there is a growing interest on the use of nanotechnology in biology and medicine because of the nanoscale range of many components of the living cells which finally leads to arise a new field – *nanomedicine*. Nanomedicine based strategies have provided new alternatives for prevention, diagnosis, and therapy of a variety of complicated diseases. At present FDA has approved a number of nanomedicine products which are commercialized in the market.

Carbonnanotubes (CNTs) – hollow cylindrical tubes with nanoscale diameter are one of the most promising carbon-based nanomaterials for nanoscience and nanotechnology. They are one-dimensional allotropes of carbon, made of graphitic sheets, and several millimetres in length (Hirlekar *et al.*, 2009; Singh *et al.*, 2012). Since their discovery (Iijima, 1991; Bethune *et al.*, 1993; Iijima and Ichihashi, 1993). CNTs have stimulated a substantial attention worldwide in the nanotechnology revolution, owing to their small size and mass, high surface area-to-volume ratio, high chemical and thermal stability, extraordinary mechanical strength, superb physico-mechanical properties, flexible interaction with cargo, biocompatibility, high electrical and thermal conductivity, diverse optical properties (Zhang *et al.*, 2010; Chen *et al.*, 2011; Movia and Giordani, 2012; Usui *et al.*, 2012; Alshehri *et al.*, 2016; Costa *et al.*, 2016; Singh B, 2016;) etc. Due to having these inimitable characteristics CNTs have a wide range of applications in different disciplines of science ranging from materials, engineering, electronics, optoelectronics, photonics, space, biotechnology, pharmaceutical industries to medicine, molecular and biological systems etc. They are well suited for biomedical applications especially in nanomedicine for prevention and treatment of several diseases. The high aspect ratio and the rich electronic polyaromatic structure of these needle-like CNTs make them suitable candidates to penetrate cellular membranes efficiently and safely with a high loading capacity of multifunctional therapeutics, including drugs, genes, and targeting molecules etc. (Hirlekar *et al.*, 2009; Zhang *et al.*, 2010; Singh *et al.*, 2012, Usui *et al.*, 2012). They do not cause any cytotoxic effect to the cells (Kostarelos *et al.*, 2007). The presence of sp^2 hybridized carbons in the CNTs enables them to functionalize with almost all biomolecules like proteins, nucleic acids, drugs, enzymes etc. and allows them to target cells and deliver drugs/genes under suitable environmental conditions. In addition, CNTs possess unique optical properties with high absorption in the near-infrared (NIR) window, photoluminescence (PL), and strong Raman shift (Ando, 2010) which allow them to be used in bioimaging (Hernández-Rivera M *et al.*, 2016; Wang *et al.*, 2016). In recent years CNTs have been used as a multifunctional platform for a variety of biomedical applications like therapeutic applications including myocardial therapy, bone formation, muscle and neuronal regeneration etc., tissue engineering, drug and gene delivery (He *et al.*, 2013; Rastogi *et al.*, 2014; Guo *et al.*, 2015; Fedeli *et al.*, 2016; Munk *et al.*, 2017; Ren *et al.*, 2017; Sharma *et al.*, 2017; Koh *et al.*, 2019; Liu *et al.*, 2019; Uttekar *et al.*, 2019; Zare *et al.*, 2021), phototherapy and diagnostics (Sajid *et al.*, 2016; Singh *et al.*, 2016), biosensors (Singh *et al.*, 2016), vaccine delivery (Hassan *et al.*, 2016) etc. This article has been specifically focused on the unique advantages, recent stimulating applications and developments of nanotechnology in nanomedicine, with particular attention given to the CNTs till date.

Discovery:

In 1991, CNTs – composed of multi-tubes (multi-wall tubes) were discovered by Iijima for the first time using an arc-discharge evaporation method (Iijima, 1991). He reported that the needle-like tubes grew at the carbon cathode. In 1992, another group of researchers synthesized CNTs by the same method (Ebbesen and Ajayan, 1992). The yield of the developed CNTs was 75%. Later the synthesis of abundant single-wall carbon nanotubes with diameters of about 1 nm was reported in 1993 by Iijima and Ichihashi (1993). These were formed in a carbon-arc chamber as soot-like deposits which grew in the gas phase. In the same year Bethune and co-workers reported the synthesis of CNTs of about 1.2 nm by covaporizing carbon and cobalt in an arc generator (Bethune *et al.*, 1993). The as-prepared CNTs had uniform and single-atomic-layer structure. Thereafter various strategies and technologies were developed to synthesize high performance CNTs that have been highlighted in the next section.

Structure of CNTs:

CNTs are considered as the fourth allotrope of carbon, following diamond, graphite and fullerene. Graphitic sheets are rolled up into seamless hollow cylinders with diameter in the range of nanometre to form CNTs where each carbon atom is bonded with sp^2 hybridization. These rolled graphene sheets are characterized by the hexagonal lattice. On the basis of the number of the concentric rolled graphitic layers CNTs are classified into single-walled carbon nanotubes (SWCNTs) and multi-walled carbon nanotubes (MWCNTs) (Figure 1). SWCNTs have only one layer of long wrapped graphene sheet, whereas the MWCNTs consist of multiple coaxial layers of single-walled tubes fixed one over other. The length of the SWCNTs is in the range of micro-meter order and the diameters varying between 0.4 and 2 nm (Bethune *et al.*, 1993; Iijima and Ichihashi, 1993). The interlayer spacing of the MWCNTs' concentric tubes is approximately 3.4 Å (Terrones, 2003). The diameter of the innermost tube is in the range of 1-3 nm, whereas the outer diameter ranges from 2-100 nm (Singh *et al.*, 2012). The length of the MWCNTs varies between 1-50 µm. Depending upon the directions of rolling up of the graphene sheets with respect to the hexagonal lattice, the SWCNTs exhibit three types of crystallographic configurations - armchair, zigzag, and chiral which differ in chiral angle and diameter (Figure 2). These variations in the configurations control the unique properties of CNTs.

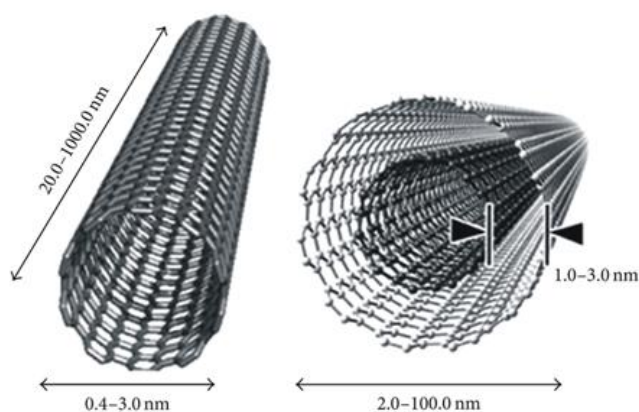

(a) (b)

Figure 1: Structure of Carbon nanotube: (a) single-walled carbon nanotube and (b) multi-walled carbon nanotube. This figure has been adapted/reproduced from [42]

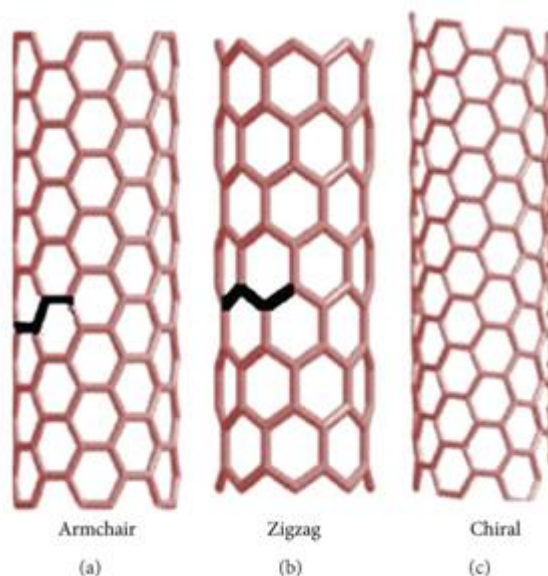

Figure 2: Carbon nanotube structures of (a) armchair, (b) zigzag and (c) chiral configurations. This figure has been adapted/reproduced from [17]

Synthesis of CNTs:

A few review articles reported the different synthesis methods of CNTs (Awasthi *et al.*, 2005; Mubarak *et al.*, 2014; Karimi *et al.*, 2015). In general, three main techniques are used for production of CNTs - Arc-Discharge method, Laser Ablation method, and Chemical Vapor Deposition (CVD) method. After preparation, various purification methods were used to purify the CNTs like chemical methods, physical methods, centrifugation, high temperature annealing etc. Two approaches are commonly used to modify the surface of CNTs – covalent and non-covalent functionalization.

In 1991, Iijima used a DC arc discharge in Ar filled vessel (100 torr) consisting of a set of carbon electrodes (Iijima, 1991) to produce MWCNTs. The discharge temperature was in the range of 2000 – 3000°C at nominal conditions of 100 A and 20 V. The production of SWCNTs by this method was reported first by Iijima and Ichihashi where Fe–graphite electrode in a CH₄-Ar atmosphere was used (Iijima and Ichihashi, 1993). Later a simplified and cost-effective carbon-arc nanotube synthesis method was reported where only a container of liquid N₂, a graphite electrode and a DC power supply were required to produce high quality MWCNTs in high yield (Ishigami *et al.*, 2000). In recent years Maria *et al.* synthesized SWCNTs by a low-frequency bipolar pulsed arc discharge method (Maria *et al.*, 2015). Interestingly, Zhang *et al.* (2018) prepared long linear carbon chains (sp hybridized) inside MWCNTs by hydrogen arc

discharge method. The synthesis of CNTs (diameter: 12.5-25 nm, length: 500-708.3 nm) under normal temperature and pressure by pulse laser ablation of graphite target in deionized water using an Nd:YAG laser at 1064 nm was reported in 2014 (Khashan and Mohsin, 2014). The formation mechanism and examples of NP synthesis by laser ablation were discussed in details by Kim *et al.* (Kim *et al.*, 2016). Recently, Khashan *et al.* prepared a composite of CNTs-iron oxide nanoparticles by two-step pulsed laser ablation in liquid using a 7ns Nd:YAG laser (1064 nm) (Khashan *et al.*, 2018). The various aspects of the aerosol-assisted CVD fabrication of MWCNTs were reported where fifteen hydrocarbons were used in combination with 1-15 wt% concentrations of catalyst (Meysami *et al.*, 2013). Shah and Tali discussed in details about the materials aspects of CCVD synthesis of CNTs like carbon sources, catalysts and substrates (Shah and Tali, 2016). Aliyu *et al.* reported the production of MWCNTs using CCVD method from a bi-metallic Fe-Ni catalyst supported on kaolin (Aliyu *et al.*, 2017). Recently CNTs with ~ 50 nm diameter were synthesized from LPG via CVD technique using an Fe₂O₃/Al₂O₃ precatalyst without H₂. The purity of the developed CNTs was about 91.2% (w/w) of hexagonal graphite (Quyem *et al.*, 2019).

Applications of CNTs in Nanomedicine:

Nowadays some of the nanoscale materials have been used extensively for clinical applications which lead to emerge a new area – nanomedicine. It is an interdisciplinary field that combines biology, chemistry, engineering and medicine. CNTs have a significant potential to be employed in nanomedicine research fields due to their unique properties such as high surface area-to-volume ratios, needle-like shapes, multifunctional surface chemistry, residual metal impurities, lack of immunogenicity, enhanced conductivity and strength, ease of functionalization, optical properties, excellent physicochemical properties, efficient drug loading capacity, ability to penetrate the cells, outstanding cell transfection capabilities, high cellular uptake etc. During last few years numerous groups reported the current developments of different types of CNTs in biomedical sectors especially in nanomedicine which are described as follows:

CNTs in Photothermal/Dynamic Therapy (PTT/PDT):

PTT is a therapeutic treatment in which thermal energy is generated through conversion of irradiating light into heat with the help of photo absorbers. This thermal energy causes thermal ablation of cells and finally kills nanomedicine-targeted cancer tissues/organs. It is a non-invasive, highly specific and selective therapy which is more advantageous than traditional therapeutic approaches for cancer treatment (Zou *et al.*, 2016). PDT is another non-invasive phototherapy for a number of cancers. It involves two non-toxic components – a special drug

namely photosensitizer (PS) that localizes to a target cell and a particular type of light of specific wavelength coming from laser or LED source. This light activates the sensitizer to produce reactive oxygen species (ROS) especially singlet oxygen ($^1\text{O}_2$) that kills cancerous and precancerous cells directly, damages blood vessels in the tumor or stimulates the resistant system (Dolmans *et al.*, 2003).

The CNTs have a high absorption cross-section of NIR light and astonishing light-to-heat energy conversion efficiency. As a result, they play a significant role in PTT (Karimi *et al.*, 2015; Singh and Torti, 2013). CNTs can either act as PSs themselves (Murakami, 2017) or be functionalized with PS molecules (Albert and Hsu, 2016). Very recently, McKernan *et al.* reported an innovative therapy of metastatic breast cancer by combining PTT with the SWCNT-ANXA5 bioconjugate and immunostimulation with an anti-CTLA-4-based checkpoint inhibitor. The ANXA5 protein minimized the amount of delivered SWCNTs required to destroy primary tumors and the developed CNTs did not cause any side effects in target organs (McKernan *et al.*, 2021). Sobhani *et al.* first oxidized MWCNTs and then used polyethylene glycol (PEG) to coat their surfaces. The as prepared O-CNT-PEG had lowest toxicity against HeLa and HepG2 cell lines. It also inhibited the growth of the murine melanoma tumor cells in mice (Sobhani *et al.*, 2017). Zhu *et al.* fabricated a novel platform based on gold nanostars decorated by MWCNTs by a green two-step reduction process to improve cancer therapy. The resulting hybrid nanomaterial showed 12.4% higher photothermal (PT) conversion efficiency and improved cancer cell ablation than the gold nanostars alone resulting in many cancer cells detaching from the substrate. This was due to the strong surface plasmon resonance absorption of this hybrid nanomaterial (Zhu *et al.*, 2018). Behnam *et al.* produced a combination of MWCNTs and silver nanorods for plasmonic photo thermal therapy (PPTT) (Behnam *et al.*, 2018). CNT/Ag NPs caused significant damage to melanoma cancer *in vivo* and therefore acted as an effective agent in PPTT method. Needa *et al.* reported a novel therapy for photothermal ablation of bladder cancer (Needa *et al.*, 2018). They conjugated SWCNTs with annexin V, which specifically bound to bladder cancer cells. The orthotopic MB 49 murine bladder tumors of the SWCNT-AV treated mice completely disappeared after 24 hrs upon NIR light treatment without causing any damage to the bladder.

The recent applications of carbon-based nanomaterials including CNTs for PDT were reviewed by Lu *et al.* (Lu *et al.*, 2018). Sundaram *et al.* developed a nanobiocomposite system composed of chlorin e6 coated hyaluronic acid (HA) based SWCNTs for efficient PDT of colon cancer cells. The resulting SWCNTs-HA-Ce6 system exhibited excellent anticancer activity against Caco-2 cells compared to free Ce6 (Sundaram and Abrahamse, 2020). Another nanocomposite based on SWCNTs and amine-functionalized porphyrin was developed which showed photodynamic effect in presence of visible light to inactivate bacterial cells. This

conjugate system could be used as an antibacterial agent for *Staphylococcus aureus* in PDT (Sah *et al.*, 2018).

CNTs in Drug and Gene Delivery:

In drug delivery mechanism, transportation of drug to a specific target in the body and interaction of drug with the target are coined together. In gene therapy, application of appropriate gene factors is the significant feature. Here a gene carrier can efficiently and selectively transport a gene to the target cells.

Due to their high surface area CNTs can adsorb or conjugate a wide variety of therapeutic and diagnostic agents (drugs, genes, vaccines, antibodies, biosensors, etc.) and, therefore, can act as effective carriers for chemotherapy and gene therapy, respectively. The CNT-based drug/gene delivery systems have potential to target tumor and kill cancer cells selectively and efficiently with very negligible side effects. Recent research on the drug/gene delivery and cellular uptake of CNTs was discussed in details by Zare *et al.* (Zare *et al.*, 2021). Liu *et al.* developed HA modified NH₂-SWCNTs loaded with anticancer drug DOX for breast cancer treatment. *In vitro* studies in MDA-MB-231 breast cancer cells showed an improved intracellular DOX delivery, better inhibition of proliferation and induction of apoptosis, and decreased cell migration (Liu *et al.*, 2019). Another drug delivery system (DDS) CPT@fCNT-RGD was prepared by Koh *et al.* which was successfully delivered to $\alpha\beta 3$ -expressing tumor cells. This DDS exhibited 3.78- and 3.02- fold increase in the anticancer effect in 2D and 3D cancer cell culture in comparison with nontargeted CPT@fCNT (Koh *et al.*, 2019). A CNT-PEG-based system conjugated with mangiferin (MF) was evaluated in terms of its usefulness against human brain cancer cells. The anticancer activity of this system was evident from 1.28-fold decrease in the IC₅₀ value. The conjugated MF on CNT-PEG platform released 59% and 50%, drug at pH 5.6 and 7.4, whereas those values for the pure MF were 74% and 59% respectively (Harsha *et al.*, 2019). Another DDS based on Folic acid (FA)-ethylene diamine (EDA) attached and acid functionalized MWCNT was synthesized to deliver DOX. This conjugate showed a significant *in vitro* anticancer activity on human breast cancer MCF-7 cells. The FA-EDA-MWCNTs-DOX compound exhibited 7.58% cytotoxicity for a 1 $\mu\text{g}/\text{mL}$ concentration and 30.31% cytotoxicity at 100 $\mu\text{g}/\text{mL}$ (Uttekar *et al.*, 2019). Li *et al.* (2018) developed pH-responsive RGD-decorated chitosan (CS) functionalized SWCNT carriers loaded with an anticancer drug DTX. This RGD-CS-SWCNT-DTX complex showed a 68% higher drug release than the pure drug at pH 5.0 and 49% at pH 7.4. It also showed excellent antitumor effect *in vitro* and *in vivo*.

A unique photoactivatable RNAi system names as (PEI-SWNT)/PhSP-shT was developed where PEI-SWNT acted as a stimulus-responsive nanocarrier and PhSP-shT acted as an Hsp70B-promoter-driver RNAi vector. This system showed excellent antitumor activity via

synergistic gene therapy and PTT (Ren *et al.*, 2017). Munk *et al.* (2017) synthesized less toxic COOH-MWCNTs to release the pDNA encoding a green fluorescent protein gene into hard-to-transfect bovine primary fibroblast cells. The COOH-MWCNTs formed complexes with pDNA which were then pervaded to the primary fibroblast cells. Guo *et al.* (2015) fabricated cationic MWCNT-NH₃⁺ which were efficient intracellular transporters for apoptotic siRNA against Polo-Like Kinase (PLK1) to destroy tumor *in vivo*. The destruction of tumor occurred due to PLK1 knockdown. A higher efficiency of PLK1 silencing was observed compared to liposomes due to a higher CNT cell penetration. Recent updates of potential biomedical applications of CNT-based hydrogels were reviewed by Vashit *et al.* (2018). However not only animal cells are involved to investigate siRNA delivery of CNTs. For example, Kwak *et al.* developed chitosan-complexed SWCNTs by using the lipid exchange envelope penetration mechanism. The as-prepared SWCNTs selectively delivered plasmid DNA into chloroplast of various plant species without any need for chemical or biolistic aid (Kwak *et al.*, 2019).

Rawal *et al.* (2019) reported CNT aided combination oncotherapy to improve cancer treatment. Nanocarrier based delivery of CNTs loaded with classical therapeutic drugs and other anticancer agents like siRNA, chemosensitizers, radiosensitizers, and antiangiogenic compounds were reported in this study. Cao *et al.* (2019) designed SWCNT-PB (SPB) based on functionalized SWCNTs in conjugation with PEI-betaine (PB) for the codelivery of DOX and survivin siRNA. It provided a great pH-responsive lysosomal escape ability for siRNA. The synergistic effects of DOX and survivin siRNA were evident from decrease in tumor volume in A549 cell-bearing nude mice treated with DOX-SPBB-siRNA and therefore, resulting in effective antitumor effect.

Conclusion:

Over the last three eras, nanotechnology has drawn a great attention in biomedical segment which finally leads to emerge a new field – nanomedicine. Nanomedicine based strategies have provided new alternatives for prevention, diagnosis, and treatment of several complicated diseases. Among an extensive range of nanomaterials, CNTs are one of the most exciting discoveries in nanotechnology and nanoscale science. By taking advantages of inimitable physical, chemical, and biological properties, CNT-based nanomaterials have been successfully employed in nanomedicine. In the present study, the remarkable applications and developments of nanotechnology in nanomedicine with the focus on CNTs have been summarized specifically in the field of drug delivery, gene delivery, photodynamic therapy and photothermal therapy. Overall, this CNT-based approach of nanotechnology has a promising potential to renovate the therapeutic perceptions in the future for the treatment of many incurable diseases.

Nevertheless, despite their wide range of biomedical applications, CNTs have few insufficiencies which need to be resolved: their heterogeneous size, inherent toxicity due to the presence of metal catalyst residue, poor solubility in water, low biodegradability and dispersivity. Therefore, in the coming years, systematic pharmacological and toxicological investigations of CNTs are required before using them for various biomedical applications.

References:

1. Albert K., Hsu H.-Y. (2016): Carbon-based materials for photo-triggered theranostic applications, *Molecules*, 21: P. 1585.
2. Aliyu A., Abdulkareem A. S., Kovo A. S. et al. (2017): Synthesize multi-walled carbon nanotubes via catalytic chemical vapour deposition method on Fe-Ni bimetallic catalyst supported on kaolin, *Carbon Lett.*, 21: P. 33.
3. Alshehri R., Ilyas A.M., Hasan A., Arnaout A., Ahmed F., Memic A. (2016): Carbon nanotubes in biomedical applications: factors, mechanisms, and remedies of toxicity, *J Med. Chem.*, 59: P. 8149.
4. Ando Y. (2010): Carbon nanotube: the inside story, *J Nanosci. Nanotechnol.*, 10(6): P. 3726.
5. Awasthi K., Srivastava A., Srivastava O. N. (2005): Synthesis of Carbon Nanotubes, *J Nanosci. Nanotechnol.*, 5: P. 1616.
6. Behnam M.A., Emami F., Sobhani Z., *et al.* (2018): Novel combination of silver nanoparticles and carbon nanotubes for plasmonic photo thermal therapy in melanoma cancer model, *Adv. Pharm. Bull.*, 8: P. 49.
7. Bethune D.S., Kiang C.H., de Vries M.D. *et al.* (1993): Cobalt-catalysed growth of carbon nanotubes with single-atomic-layer walls, *Nature*, 363: P. 605.
8. Cao Y., Huang H.Y., Chen L.Q., et al. (2019): Enhanced lysosomal escape of pH-responsive polyethylenimine–betaine functionalized carbon nanotube for the codelivery of survivin small interfering RNA and doxorubicin, *ACS Appl. Mater. Interfaces.*, 11: P. 9763.
9. Chen Z., Zhang X., Yang R., *et al.* (2011): Single-walled carbon nanotubes as optical materials for bio- sensing, *Nanoscale*, 3(5): P. 1949.
10. Costa P.M., Bourgoignon M., Wang J.T.W., Al-Jamal K.T. (2016): Functionalised carbon nanotubes: from intracellular uptake and cell-related toxicity to systemic brain delivery, *J Control Release*, 241: P.200.
11. Dolmans D.E.J.G.J., Fukumura, D., Jain, R.K. (2003): Photodynamic therapy for cancer, *Nat. Rev. Cancer.*, 3(5): P. 380.
12. Fedeli S., Brandi A., Venturini L., *et al.* (2016): The “click-on-tube” approach for the production of efficient drug carriers based on oxidized multi-walled carbon nanotubes, *J Mater. Chem. B.*, 4: P. 3823.

13. Guo C., Al-Jamal W.T., Toma F.M., *et al.* (2015): Design of cationic multiwalled carbon nanotubes as efficient siRNA vectors for lung cancer xenograft eradication, *Bioconjug. Chem.*, 26(7): P. 1370.
14. Harsha P., Thotakura N., Kumar M., *et al.* (2019): A novel PEGylated carbon nanotube conjugated mangiferin: an explorative nanomedicine for brain cancer cells, *J Drug Deliv. Sci. Technol.*, 53: P. 101186.
15. Hassan H.A.F.M., Smyth L., Rubio N., *et al.* (2016): Carbon nanotubes' surface chemistry determines their potency as vaccine nanocarriers in vitro and in vivo, *J Control Release.*, 225: P. 205.
16. Ebbesen T. W., Ajayan P. M. (1992): Large-scale synthesis of carbon nanotubes, *Nature*, 358: P. 220.
17. He H., Huy L.A.P., Dramou P., *et al.* (2013): Carbon Nanotubes: Applications in Pharmacy and Medicine, *BioMed Res. Int.*, DOI: 10.1155/2013/578290.
18. Hernández-Rivera M., Zaibaq N.G., Wilson L.J. (2016): Toward carbon nanotube-based imaging agents for the clinic, *Biomaterials*, 101: P. 229.
19. Hirlekar R., Yamagar M., Garse H., Vij M., *et al.* (2009): Carbon nanotubes and its applications: a review," *Asian Journal of Pharmaceutical and Clinical Research*, *Asian J Pharm. Clin. Res.*, 2(4): P. 17.
20. Iijima S. (1991): Helical microtubules of graphitic carbon, *Nature*, 354(6348): P. 56.
21. Iijima S., Ichihashi T. (1993): Single-shell carbon nanotubes of 1-nm diameter, *Nature*, 363: P. 603.
22. Ishigami M., Cumings J., Zettl A., *et al.* (2000): A simple method for the continuous production of carbon nanotubes, *Chem. Phys. Lett.*, 319(5): P. 457.
23. Karimi M., Solati N., Amiri M., *et al.* (2015): Carbon nanotubes part I: preparation of a novel and versatile drug-delivery vehicle, *Expert Opin. Drug Deliv.*, 12 (7): P. 1071.
24. Khashan K. S., Mohsin M.H. (2014): Preparation of carbon nanotube by pulse laser ablation of graphite target in deionized water, *Eng. & Tech. Journal.*, 32. Part (B) (1): P. 61.
25. Khashan K. S., Sulaiman G.M., Mahdi R., Kadhim A. (2018): The effect of laser energy on the properties of carbon nanotube-iron oxide nanoparticles composite prepared via pulsed laser ablation in liquid, *Mater. Res. Express.*, 5: P. 105004.
26. Kim M., Osone S., Kim T., Higashi H., Seto T. (2016): Synthesis of Nanoparticles by Laser Ablation: A Review, *KONA Powder Part. J.*, 34(2017): P. 80.
27. Koh B., Park S.B., Yoon E., *et al.* (2019): $\alpha V\beta 3$ -targeted delivery of camptothecin-encapsulated carbon nanotube-cyclic RGD in 2D and 3D cancer cell culture, *J Pharm. Sci.*, 108: P. 3704.

28. Kostarelos K., Lacerda L., Bianco A. (2007): Cellular uptake of functionalized carbon nanotubes is independent of functional group and cell type, *Nat. Nanotechnol.*, 2(2): P. 108.
29. Kwak S.Y., Lew T.T.S., Sweeney C.J., *et al.* (2019): Chloroplast-selective gene delivery and expression in planta using chitosan-complexed single-walled carbon nanotube carriers, *Nat. Nanotechnol.*, 14: P. 447.
30. Li B., Zhang X.X., Huang H.Y., *et al.* (2018): Effective deactivation of A549 tumor cells in vitro and in vivo by RGD-decorated chitosan-functionalized single-walled carbon nanotube loading docetaxel *Int. J Pharm.*, 543: P. 8.
31. Liu D., Zhang Q., Wang J., *et al.* (2019): Hyaluronic acid-coated single-walled carbon nanotubes loaded with doxorubicin for the treatment of breast cancer, *Pharmazie*, 74(2): P. 83.
32. Lu D., Tao R., Wang Z. (2018): Carbon-based materials for photodynamic therapy: A mini-review, *Front. Chem. Sci. Eng.*, 13: P. 310.
33. Maria K.H., Mieno T. (2015): Synthesis of single-walled carbon nanotubes by low-frequency bipolar pulsed arc discharge method *Vacuum.*, 113: P. 11.
34. McKernan P., Virani N. A., Faria G.N.F., *et al.* (2021): Targeted SWCNTs for PTT combined with immune checkpoint inhibition for the treatment of metastatic breast cancer, *Nanoscale Res. Lett.* 16: P. 9.
35. Meysami S. S., Dillon F., Koos A.A., Aslam Z., Grobert N. (2013): Aerosol-assisted chemical vapour deposition synthesis of multi-wall carbon nanotubes: II. An analytical study, *Carbon*, 58: P. 159.
36. Movia D., Giordani S. (2012). Toxicity of carbon nanotubes. (Perosa A., Selva M. eds.), *Handbook of Green Chemistry*. pp. 175–216. Wiley, Weinheim, Germany.
37. Mubarak N.M., Abdullah E.C., Jayakumar N.S., Sahu J.N. (2014): An overview on methods for the production of carbon nanotubes, *J Ind. Eng. Chem.*, 20(4): P. 1186.
38. Murakami T. (2017): Photodynamic action of single-walled carbon nanotubes, *Chem. Pharm. Bull.*, 65: P. 629.
39. Munk M., de Souza Salomão R., Zanette L.S., *et al.* (2017): Using carbon nanotubes to deliver genes to hard-to-transfect mammalian primary fibroblast cells, *Biomed. Phys. Eng. Express.*, 3: P. 045002.
40. Needa A.V., Carole D., Patrick M., *et al.* (2018): Phosphatidylserine targeted single-walled carbon nanotubes for photothermal ablation of bladder cancer, *Nanotechnology*, 29(3): P. 035101.

41. Quyen N.D.V., Khieu D. Q., Tuyen T.N., Tin D.X., Diem B.T.H. (2019): Carbon nanotubes: synthesis via chemical vapour deposition without hydrogen, surface modification, and application, *J Chem.*, <https://doi.org/10.1155/2019/4260153>.
42. Rastogi V., Yadav P., Bhattacharya S. S., *et al.* (2014): Carbon Nanotubes: An emerging drug carrier for targeting cancer cells, *J Drug Deliv.*, 6348: P. 670815.
43. Rawal S., Patel M.M. (2019): Threatening cancer with nanoparticle aided combination oncotherapy, *J Control Release.*, 301: P. 76.
44. Ren X., Lin J., Wang X., *et al.* (2017): Photoactivatable RNAi for cancer gene therapy triggered by near-infrared-irradiated single-walled carbon nanotubes, *Int. J Nanomed.*, 12: P. 7885.
45. Sah U., Sharma K., Chaudhri N., Sankar M., Gopinath P. (2018): Antimicrobial photodynamic therapy: Single-walled carbon nanotube (SWCNT)-Porphyrin conjugate for visible light mediated inactivation of *Staphylococcus aureus*, *Colloids Surf. B*, 162: P. 108.
46. Sajid M.I., Jamshaid U., Jamshaid T., *et al.* (2016): Carbon nanotubes from synthesis to in vivo biomedical applications, *Int. J Pharm.*, 501: P. 278.
47. Shah K.A., Tali B.A. (2016): Synthesis of carbon nanotubes by catalytic chemical vapour deposition: A review on carbon sources, catalysts and substrates, *Mater. Sci. Semicond. Proc.*, 41: P. 67.
48. Sharma P., Jain K., Jain N.K., Mehra N.K. (2017): Ex vivo and in vivo performance of anti-cancer drug loaded carbon nanotubes, *J Drug Deliv. Sci. Tech.*, 41: P.134.
49. Singh B., Lohan S., Sandhu P.S., Jain A., Mehta S.K. (2016): Functionalized carbon nanotubes and their promising applications in therapeutics and diagnostics. (Grumezescu A.M. editor.) *Nanobiomaterials in Medical Imaging*. pp. 455–478. William Andrew Publishing.
50. Singh B.G. P., Baburao C., Pispati V., *et al.* (2012): Carbon nanotubes-a novel drug delivery system, *Int. J. Res. Pharm. Chem.*, 2(2): P. 523.
51. Singh R., Torti S.V. (2013): Carbon nanotubes in hyperthermia therapy, *Adv. Drug Deliv. Rev.* 65: P. 2045.
52. Sobhani Z., Behnam M.A., Emami F., Dehghanian A., Jamhiri I. (2017): Photothermal therapy of melanoma tumor using multiwalled carbon nanotubes, *Int. J Nanomed.* 12: P. 4509.
53. Sundaram P., Abrahamse H. (2020): Effective PDT for colon cancer cells using Ce6 coated HA based CNT, *Int. J Mol. Sci.*, 21(13): P. 4745.
54. Terrones M. (2003): Science and technology of the twenty-first century: synthesis, properties, and applications of carbon nanotubes, *Annu. Rev. Mater. Res.*, 33: P. 419.

55. Usui Y., Haniu H., Tsuruoka S., Saito N. (2012): Carbon nanotubes innovate on medical technology *Med. Chem.*, 2(1): P. 1.
56. Uttekar P.S., Lakade S.H., Beldar V.K., Harde M.T. (2019): Facile synthesis of multi-walled carbon nanotube via folic acid grafted nanoparticle for precise delivery of doxorubicin, *IET Nanobiotechnol.*, 13: P. 688.
57. Vashist A., Kaushik A., Vashist A., *et al.* (2018): Advances in Carbon Nanotubes–Hydrogel Hybrids in Nanomedicine for Therapeutics, *Adv. Healthcare Mater.*, 7: P. 1701213.
58. Wang Y., Liu J., Cui L., Losic D. (2016): Cytotoxicity, drug delivery, and photothermal therapy of functionalized carbon nanomaterials. (Zhang M., Naik R.R., Dai L. eds.) *Carbon Nanomaterials for Biomedical Applications*. Pp 81-111. Cham: Springer International Publishing.
59. Zare H., Ahmadi S., Ghasemi A., *et al.* (2021): Carbon Nanotubes: Smart Drug/Gene Delivery Carriers, *Int. J Nanomed.*, 16: P. 1681.
60. Zhang W., Zhang Z., Zhang Y. (2011): The application of carbon nanotubes in target drug delivery systems for cancer therapies, *Nanoscale Res. Lett.*, 6: P. 555–577.
61. Zhang Y., Bai Y., Yan B. (2010): Functionalized carbon nanotubes for potential medicinal applications, *Drug Discov. Today*, 15 (11-12): P. 428.
62. Zhang Y., Zhao J., Fang Y., Liu Y., Zhao X. (2018): Preparation of long linear carbon chain inside multi-walled carbon nanotubes by cooling enhanced hydrogen arc discharge method, *Nanoscale.*,10: P. 17824.
63. Zhu Y., Sun Q., Liu Y., *et al.* (2018): Decorating gold nanostars with MWCNTs for PTT, *R. Soc. Open Sci.*, 5 (8): P. 180159.
64. Zou L., Wang H., He B. *et al.* (2016): Current approaches of photothermal therapy in treating cancer metastasis with nanotherapeutics, *Theranostics*, 6: P. 762.

ORGANOCATALYSIS: AN IMPORTANT STRATEGIC TOOL FOR TOTAL SYNTHESSES

Venkatesh B. Gopula

Department of Chemistry

Anandibai Raorane Arts, Commerce and Science College,

Vaibhavwadi, Dist. Sindhudurg (MH) – 461810

Corresponding author E-mail: gopulavenkatesh@gmail.com

Introduction:

Organocatalysis refers to a form of catalysis, whereby the rate of a chemical reaction is increased by an organic catalyst referred to as an "organocatalyst" consisting of carbon, hydrogen, sulfur and other nonmetal elements found in organic compounds. Over the last decade, catalysis of reactions by simple metal-free organic molecules (organocatalysis) has become an important area of research. Although organocatalysis frequently require a high catalyst loading and long reaction times, compare with catalysts made of metal complexes, organocatalysts show many extraordinary advantages including their lack of sensitivity to moisture and oxygen, their ease of preparation, low toxicity and less expensive.¹ All of these advantages are attractive towards the synthesis of pharmaceutical intermediates. Basically, organocatalysts can be divided into four types based on their modes of activation: Lewis bases, Lewis acids, Bronsted bases, and Bronsted acids. Since the rediscovery of organocatalysis at the dawn of the new millennium an exponential number of papers on this subject appeared over the years.² It generated several excellent reviews and books where various aspects of this field have been dissected.^{3,4} Pavel Kocovsky pointed out that while the words "asymmetric" and "organocatalysis" were closely connected in the minds of the many scientists working in this field, chiral compounds are not the only important ones which can be easily prepared employing this methodology.⁵ The well-known attractive aspects of organocatalysis such as environmentally friendly conditions (no need for anhydrous conditions or of transition metals)³ without any doubt apply also to transformations affording achiral molecules as products.

This field is still in its early years, researchers are now starting to "think organocatalytic" when applying disconnecting strategies to total syntheses. Some non-asymmetric organocatalytic reactions are so surprising that they could not have been foreseen at the beginning of their relevant project. In several cases the achiral products are the undesired side

products in an asymmetric transformation. As it has happened several times before, coincidence brought a significant advance in science⁶

Types of organocatalysts:

Broadly speaking the organocatalysts can be classified into four main categories, (Figure-1.1) they are

1. Lewis Base catalyst,
2. Lewis Acid catalyst,
3. Bronsted Base catalyst and
4. Bronsted Acid catalyst

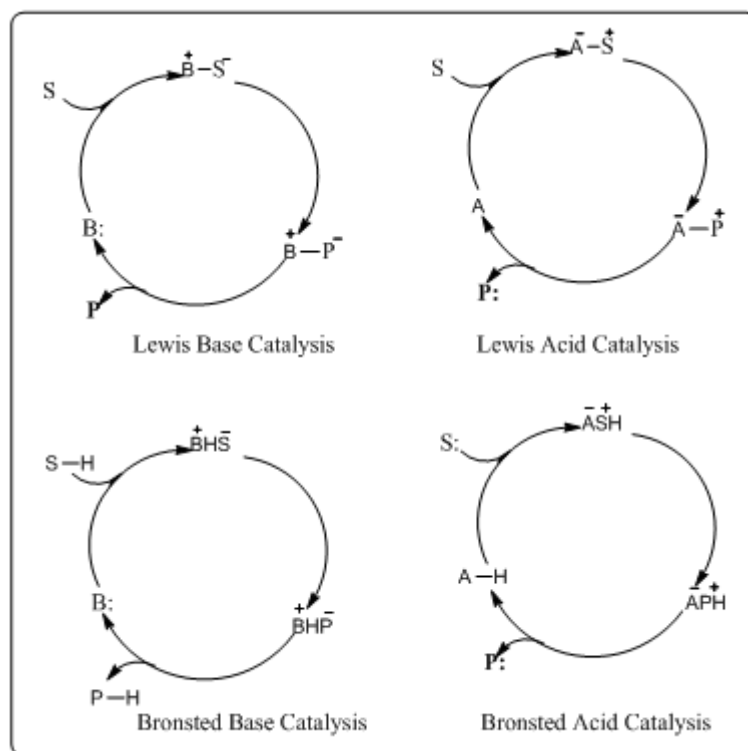

Figure 1.1: Types of organocatalysts

Lewis Basic Organocatalysts and Organocatalysis:

Various bases have been reported in the literature as an efficient organocatalysts. These include the iminium ion, phosphine, cyclic amino acids such as proline etc. The important examples of Lewis base organocatalysis have been discussed below.

a) Diels-Alder Reaction:

Group of MacMillan reported first enantioselective organocatalytic Mukaiyama-Michael reaction leading to the direct access to enantioenriched γ -butenolide architecture via the 1,4

addition of substituted furan to α,β -unsaturated enals catalysed by imidazolidinone catalyst⁷ (iminium ion), **scheme-1.1**. In Diels-Alder reactions, α,β -unsaturated carbonyl compounds as diene and 1,4-cyclopentadiene as dienophiles had also been reported by analogous catalyst⁸ but with 5-methylfuryl substituent instead of *t*-butyl group, (**scheme-1.2**)

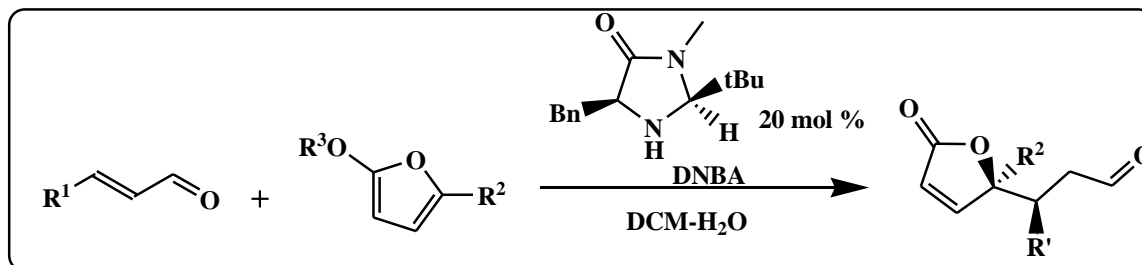

Scheme-1.1

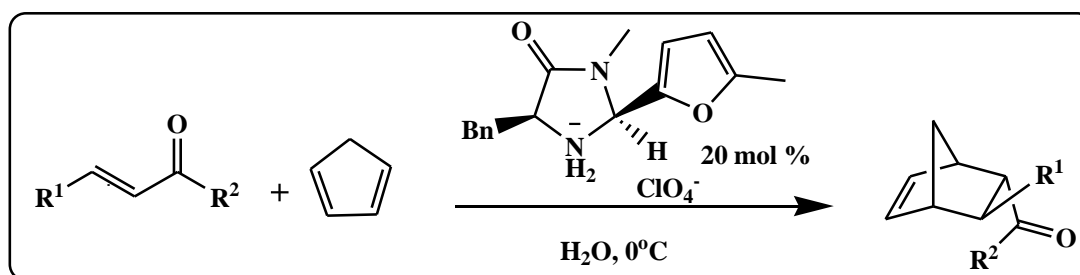

Scheme-1.2

b) Friedel-Craft Alkylation of Pyrrole

To further demonstrate the potential of iminium-catalysis strategy, the group of MacMillan reported an asymmetric Friedel-Craft alkylation of pyrrole and indole, a variant that is currently unavailable using acid or metal catalysis. The reaction is common as it has wide scope with substituents on both, aldehydes as well as pyrrole⁹ such as alkyl, alkoxy, benzyloxy and ester were well tolerated along with good to excellent yields and enantioselectivity, (**scheme-1.3**)

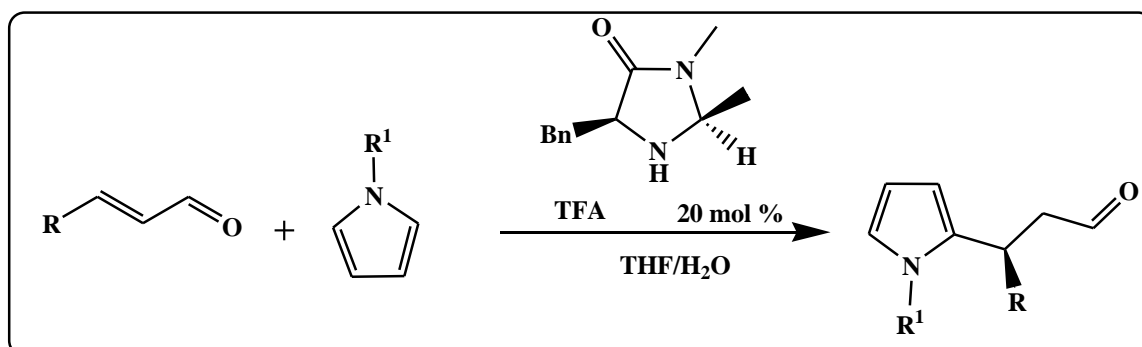

Scheme-1.3

c) **Aldol Reaction (Ketone-Aldehyde aldol)**

Aldol condensation constitutes one of the key organic reactions leading to highly versatile β -hydroxy aldehyde or ketone building blocks. One of the versatile utilities of organocatalysis is the aldol condensation reaction. List *et. al.*¹⁰ reported the L-proline catalysed asymmetric aldol condensation of enolisable ketone and aldehydes, (**scheme-1.4**). In addition the organocatalysis has been successfully achieved for Mannich reaction¹¹ using similar types of catalyst, (**scheme - 1.5**).

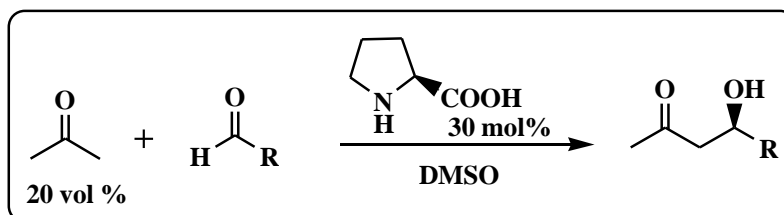

Scheme- 1.4

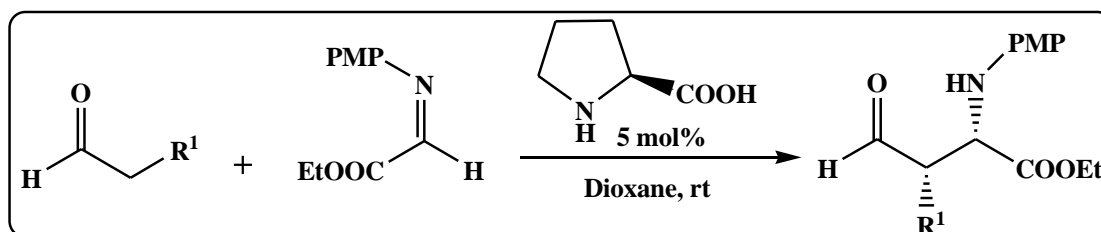

Scheme-1.5

Lewis Acidic Organocatalysts and Organocatalysis:

An additional useful category of organocatalysis is Lewis acid organocatalysis, several efficient Lewis acid types of organocatalysts have been emerged recently. These include the phosphorous, nitrogen and boron based catalysts.

Some selected examples of Lewis acid organocatalysis are discussed below

a) **Michael addition**

Maruoka *et al.*¹² reported the Chiral ammonium bifluorides as extremely efficient organocatalyst for highly enantioselective Michael addition of silyl nitronates to α, β -unsaturated aldehydes. This protocol provided the access to optically active γ -nitro aldehydes and their enol silyl ethers in high to excellent yields, (**scheme-1.6**).

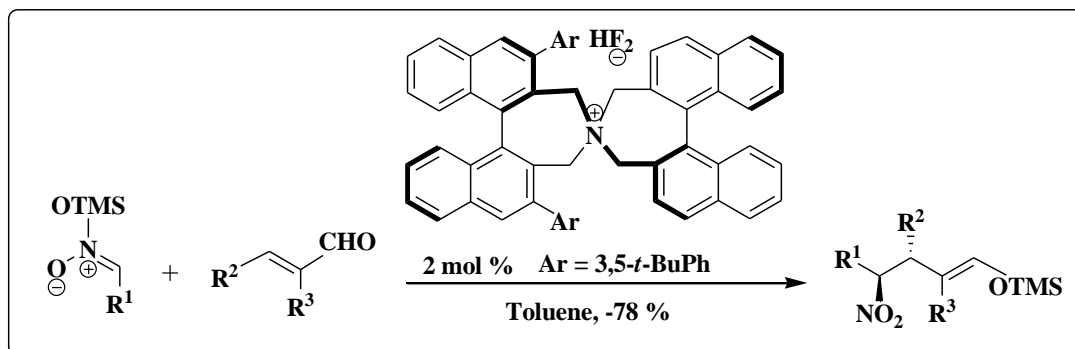

Scheme-1.6

b) **Epoxidation**

Lewis acidic catalyst such as cyclic amino ester α-fluoro-*N*-carbethoxytropinone¹³ has been reported for the epoxidation of alkenes. The reaction proceeded efficiently and to afford wide variety of oxiranes in good to excellent yields and reasonably high enantiomeric excess, (scheme-1.7).

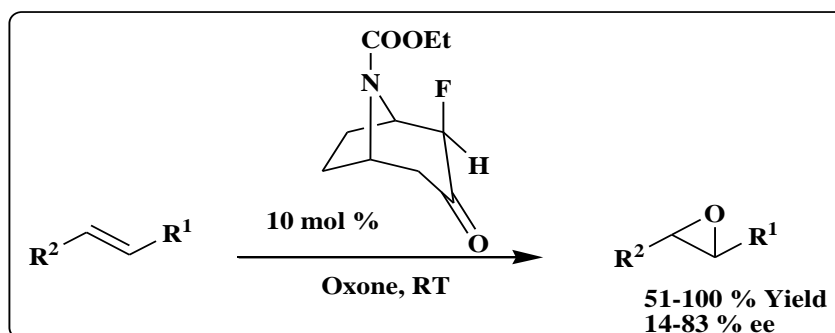

Scheme-1.7

c) **In situ Enamine: Michael Addition (Addition to nitroalkenes)**

The direct Michael addition of α-hydroxyketones to β-arylnitroolefins catalyzed by *N*-*i*Pr-2,2'-bipyrrolidine is reported by the Alexakis group¹⁴, (scheme-1.8). In this tertiary nitrogen of the catalyst leads to the formation of enamine intermediate that tells the diastereoselectivity and very high ee's.

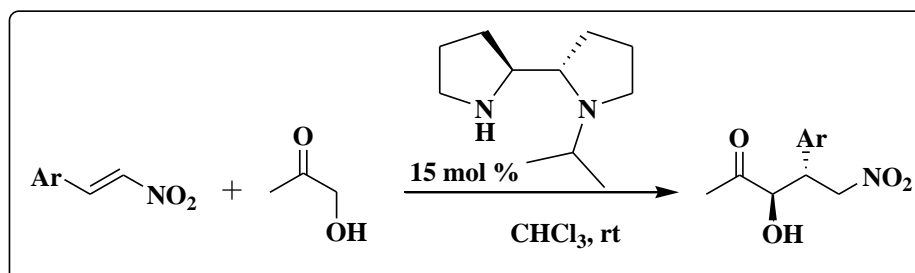

Scheme- 1.8

d) *In situ* Enamine: Oxidations (α -Amination)

The β -amino alcohols are considered to be highly versatile building blocks in organic synthesis. The organocatalysed stereoselective process for β -amino alcohol have been recently developed by group of List¹⁵ in which the addition of enolisable aldehyde to Cbz protected carbodiimide using S-proline followed by reduction afforded the β -amino alcohol in excellent yield and distereoselectivity, (**scheme -1.9**).

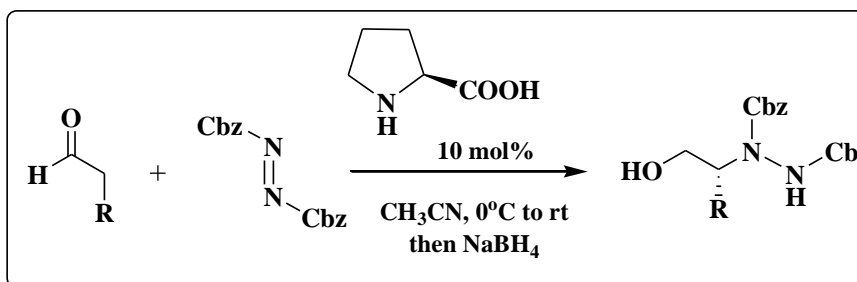
**Scheme- 1.9****Bronsted Basic Organocatalysis:**

As compared to Bronsted acidic catalysis the information on the Bronsted basic organocatalysis are relatively scarce. In 2000, the group of Deng¹⁶ reported the cinchona alkaloid catalysed enantioselective opening of readily accessible prochiral cyclic anhydrides. The chiral hemiester with one or multiple stereogenic centres and two distinct functionalities were readily obtained in high to excellent yields and enantiomeric excess. (**Scheme-1.10**).

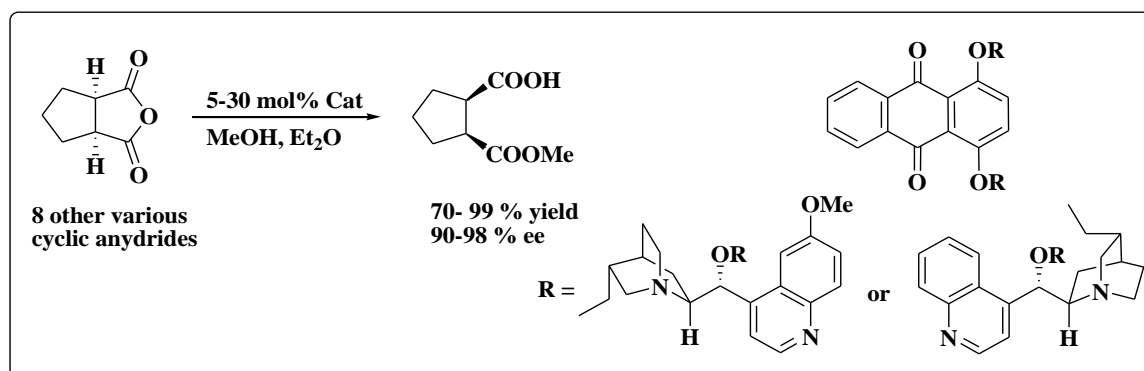
**Scheme-1.10****Bronsted Acidic Organocatalysis:**

Recently, Jacobsen *et al.* have developed highly enantioselective Strecker reactions¹⁷ and Mannich reactions¹⁸ catalyzed by peptide-based thiourea derivatives as chiral Brønsted acids. The Bronsted acid organocatalysis has been recently extensively studied and well documented in

the literature. A plethora of Bronsted acid based on phosphorus and boron in particular, chiral catalyst have been synthesized in their pioneer work by group of List.

The various Bronsted acid catalysed reactions have been reviewed below

a) Addition of active methylene compound to imine

In 2004, Terada. *et al.*¹⁹ reported the binol phosphoric acid derivatives which serve as highly effective catalyst for the direct addition of acetyl acetone to *N*-Boc-protected arylimines to construct the β -aminoketones in excellent yields and enantioselective under extremely mild conditions, (**scheme-1.11**).

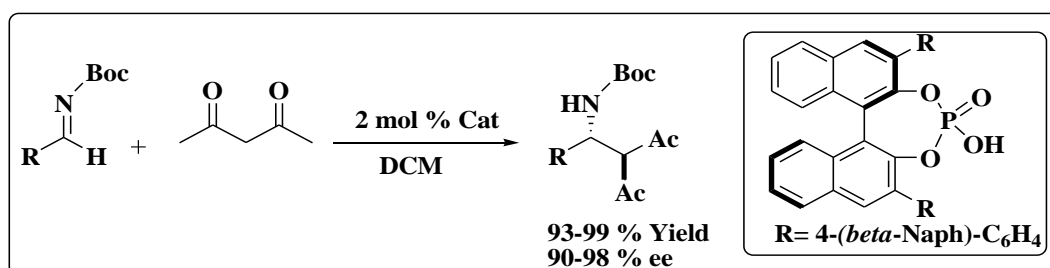

Scheme-1.11

b) Reductive amination of aldehydes and ketones

In 2006, MacMillan *et al.*²⁰ first of all developed the enantioselective organocatalytic reduction amination of aldehydes and ketones in the presence of Hantzsch ester mediated by binol based phosphoric acid catalyst in good to high yield. The method was found to be highly stereoselective as it provided the corresponding 2^o amine in high to excellent enantiomeric excess, (**scheme-1.12**).

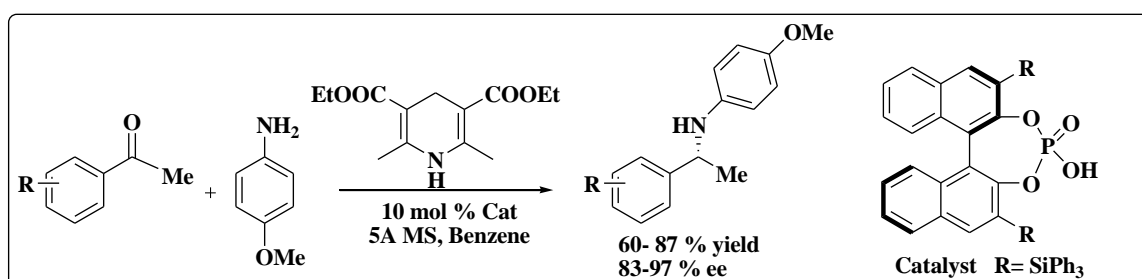

Scheme-1.12

c) Micheal Addition

In 2003, Takemoto *et al.*²¹ reported the thiourea derivative catalyst as a bifunctional organocatalyst which promoted the Micheal reaction of malonates to various nitroolefins to give nitro malonates derivatives in good to high yields and excellent enantioselectivity, (**scheme-1.13**).

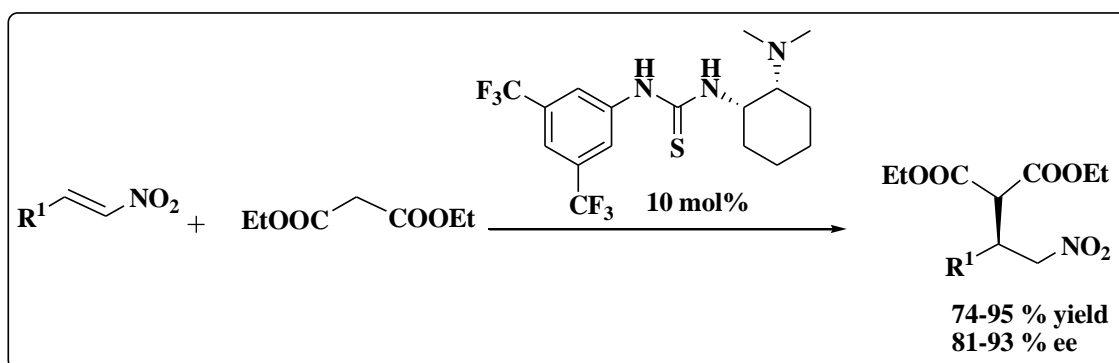

Scheme-1.13

d) Morita-Baylis-Hillman

Schaus *et al.*²² in 2003, developed a highly enantioselective asymmetric Morita-Baylis-Hillman reaction involving the addition of cyclohexenone to aldehydes catalysed by a chiral BINOL derived Bronsted acid and yields were obtained in good to excellent with excellent enantiomeric excess, (**scheme-1.14**).

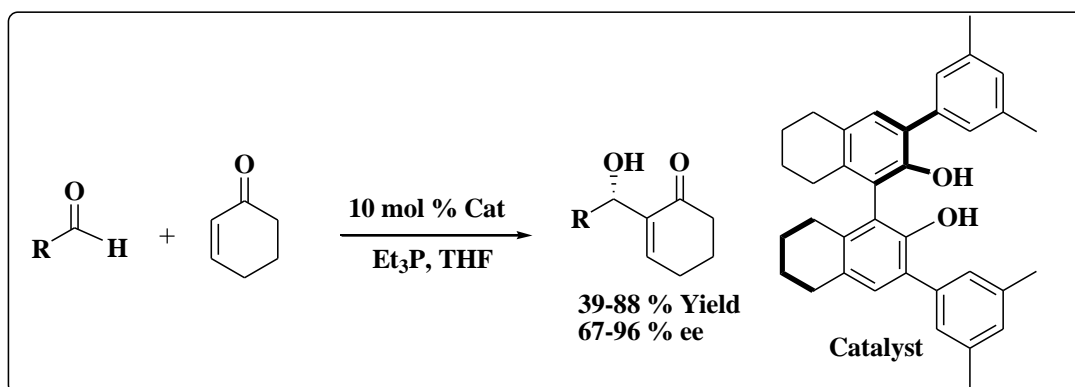

Scheme-1.14

References:

- 1 MacMillan (2008) *Nature*, 455, 304–308; b) Allen and MacMillan (2012) *Chem. Sci.* **2012**, 3, 633–658.
- 2 Key papers: a) List, B.; Lerner, R. A.; Barbas III, C. F. (2000) *J. Am. Chem. Soc.*, 122, 2395; b) List, B.; Notz, W. (2000) *J. Am. Chem. Soc.*, 122, 7386; c) Ahrendt, K. A.; Borths, C. J.; MacMillan, D. W. C. (2000) *J. Am. Chem. Soc.*, 122, 4243; d) Kumaragurubaran, N.; Juhl, K.; Zhuang, W.; Borgevig, A.; Jorgensen, K. A. (2002) *J. Am. Chem. Soc.*, 124, 6254.
- 3 a) Berkessel, A.; H. Groger, *Asymmetric Organocatalysis: from Biomimetic Concepts to Applications in Asymmetric Synthesis*, Wiley-VCH, **2005**; b) Pellissier, H. *Recent*

- Developments in Asymmetric Organocatalysis*, RSC Publishing, **2010**. Selected reviews: (c) Albrecht, L.; Jiang, H.; Jorgensen, K. A. (2011) *Angew. Chem., Int. Ed.*, *50*, 8492; d) Hegedus, L. S. (2009) *J. Am. Chem. Soc.*, *131*, 17995; e) Bertelsen, S.; Jorgensen, K. A. (2009) *Chem. Soc. Rev.*, *38*, 2178; f) Dondoni, A.; Massi, A. (2008) *Angew. Chem., Int. Ed.*, *47*, 4638; g) Melchiorre, P.; Marigo, M.; Carlone, A.; Bartoli, G. (2008) *Angew. Chem., Int. Ed.*, *47*, 6138; h) Dalko, P. I.; Maison, L. (2004) *Angew. Chem., Int. Ed.*, *43*, 5138.
- 4 A non-exhaustive list includes over 3600 research papers and over 300 reviews containing the keyword “organocatalysis” according to Scopus Database (Feb 2012, www.scopus.com).
- 5 Introductory speech, International Symposium on Organocatalysis in Organic Synthesis, University of Glasgow, UK, 5–7 July 2006.
- 6 Roberts, R. M. *Serendipity: Accidental Discoveries in Science*, Wiley, New York, 1989.
- 7 Brown, S. P.; Goodwin, N. C.; MacMillan, D. W. C. (2003) *J. Am. Chem. Soc.*, *125*, 1192-1194.
- 8 Ahrendt, K.A.; Borths, C. J.; Macmillan, D. W. C.,(2000) *J. Am. Chem. Soc.*,*122*, 4243-4244.
- 9 Paras, N. A.; MacMillan, D. W. C. (2001), *J. Am. Chem. Soc.*, *123*, 4370-4371
- 10 List, B.; Lerner, R. A.; Barbas III, C. F. (2000), *J. Am. Chem. Soc.*, *122*, 2395-2396
- 11 Notz, W.; Tanaka, F.; Watanabe, S.-I.; Chowdari, N. S.; Turner, J. M.; Thayumanavan, R.; Barbas III, C. F. (2003) *J. Org. Chem.*, *68*, 9624-9634.
- 12 Ooi, T.; Doda, K.; Maruoka, K. (2003) *J. Am. Chem. Soc.*, **2003**, *125*, 9022-9023.
- 13 Armstrong, A.; Ahmed, G.; Dominguez-Fernandez, B.; Hayter, B. R.; Wailes, J. S. (2002) *J. Org. Chem.*,*67*, 8610-8617
- 14 Olivier, A.; Alexandre, A.; Gerald, B. (2003) *Org. Lett.* *5*, 2559-2561
- 15 List, B. (2002) *J. Am. Chem. Soc.**124*, 5656
- 16 Chen, Y.; Tian, S.-K.; Deng, L. (2000) *J. Am. Chem. Soc.*, *122*, 9542-9543
- 17 Sigman, M. S.; Vachal, P.; Jacobsen, E. N. (2000) *Angew. Chem.* *112*, 1136-38
- 18 Wenzel, A. G.; Jacobsen, E. N. (2002) *J. Am. Chem. Soc.*, *124*, 12964-12965
- 19 Terada, M. (2004) *J. Am. Chem. Soc.* 5356
- 20 MacMillan, D. (2005) *J. Am. Chem. Soc. ASAP* other examples of reductive amination: Reuping, M. *Org. Lett.*, 378; List, B. (2005) *Angew. Chem. Int. Ed.* 7424
- 21 Takemoto, Y. (2004) *Org. Lett.*, 625.
- 22 Schaus, S. (2003) *J. Am. Chem. Soc.*, 12094.

STUDY OF LORENTZ TRANSFORMATION EQUATIONS FOR SPACE AND TIME

Sanjay Singh

Department of Physics,
Chintamani College of Arts and Science,
Gondpipri, Dist. Chandrapur (M.S.) India

Corresponding author E-mail: sanjayavantika1979@gmail.com

Abstract:

Lorentz Transformation Equations, Special theory of relativity and general theory of relativity published by Einstein. The laws of physical phenomena are the same in all frames of reference moving at constant velocity relative to each other. The speed of light in free space is the same for all observers and is independent of the inertial system, the source and the observers.

Introduction:

Prominence of Lorentz Transformation equations, when an objects starts upcoming the speed of light Newtonian physics starts to collapse. e.g. If we think of a offered situation where the Sun was to cease to exist at this every moment, according to Newton's law of gravitation ,the earth would feel its impact instantaneously. However we know it is not possible. But in Galilean transformation, the speed of light perceived differently depending on the frame of reference. We know that nobodyalwaysmovementsmore rapidly than the speed of light. Thus there was a contradiction which formulated the need to develop a different set of transformation equation

The relationship between two different coordinate frames that move at a constant velocity and are relative to each other is called the Lorentz transformations. Einstein has published there two separate theories of relativity. First theory as Special theory of relativity, published in the year 1905. Here the word special is implies that the theory considers the phenomena only in inertial frame of reference. And second theory as general theory of relativity published in the year 1915. In this theory there are covers accelerated frame of reference as well as provides a new concepts on the phenomena of gravitation.

The special theory of relativity is based on the following two postulates.

(1) The laws of physics are invariant (same) in all inertial frame of reference.

According to this, the laws of physical phenomena are the same in all frames of reference moving at constant velocity relative to each other it means; all inertial systems are equivalent to express the laws of physics.

or

“The Einstein’s principle of relativity establishes the complete equality of all inertial frames and rejects the Newton’s ideas of absolute space and absolute motion.”

(2)The speed of light in free space is the same (constant) for all observers and is independent of the inertial system, the source and the observer. Again we can say

The speed of light in free space is the same for all observers and is independent of the inertial system, the source and the observers.

Lorentz transformations area set of transformation equations based on the postulates of special theory of relativity

Derivation:

The change in the inertial frames is only related to Lorentz transformation, usually in the context of special relativity. This transformation is a type of linear transformation in which mapping occurs between 2 modules that include vector spaces. In linear transformation, the operations of scalar multiplication and additions are preserved. This transformation has a number of instinctive features, such as the observer that is moving at different velocity may measure elapsed times, different distances, and ordering of events but the condition that needs to be followed is that the speed of light should be the same in all the inertial frames.

Lorentz transformations can also comprise revolution of space; a revolution that is free of this transformation is called Lorentz Boost. The space-time interval which occurs between any two events is preserved by this transformation

Let L and L' be the two rectangular inertial frames of reference with their axes OX and O'X' collinear.

Let V is the uniform velocity of the frame L' relative to L, in the positive X- direction. Suppose the two origins O and O' coincide at time, $t = t' = 0$

At that instant, a pulse of light is initiated from the source, which is at the origin O of the frame L.

Since the speed of light is constant, we have

For the observer at O in the frame L,

$$x=ct \quad \dots\dots\dots(1)$$

Since, $\text{Time} = \frac{\text{Distance}}{\text{Speed}}$

For the observer at O' in the frame L'

$$x' = c t' \dots\dots\dots(2)$$

Since there is one relative velocity v , the transformation equations must be satisfying the following conditions.

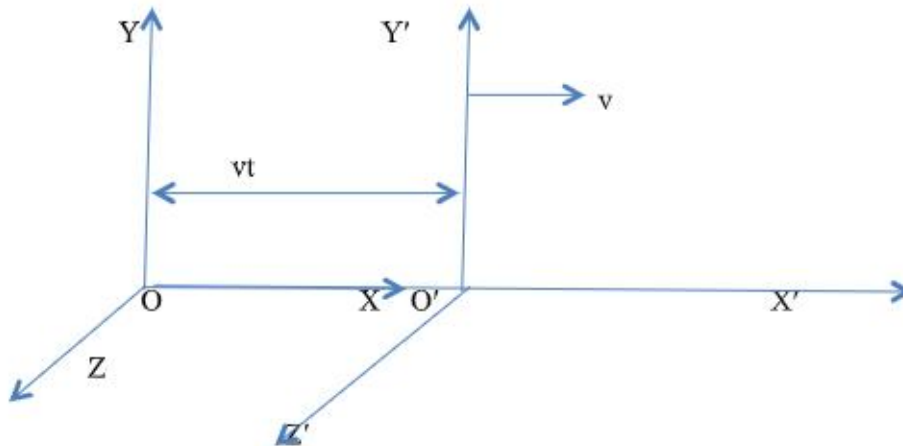

- (i) The coordinates of O' in the frame L is vt .
- (ii) The coordinates of O in the frame L' is $-vt'$.

The simplest equations which satisfy these conditions are as followings

$$x' = k(x - vt) \dots\dots\dots(3)$$

and

$$x = k(x' + vt) \dots\dots\dots(4)$$

The factor k must be same in the both frames

As the relative motion of L and L' is confined to only X -direction

$$y' = y \text{ and } Z' = Z$$

Substituting the value of t and t' from equation (1) and (2) in equation (3) and (4), we get

$$x' = k(x - \frac{vx}{c}) = k x(1 - \frac{v}{c}) \dots\dots\dots(5)$$

$$x = k(x' + \frac{vx'}{c}) = k x'(1 + \frac{v}{c}) \dots\dots\dots(6)$$

On multiplying equations (5) and (6), we get

$$x' x = k^2 x x'(1 - \frac{v^2}{c^2})$$

$$k^2 = \frac{1}{(1 - \frac{v^2}{c^2})}$$

$$k = \frac{1}{\sqrt{(1-\frac{v^2}{c^2})}} \dots\dots\dots(7)$$

On substituting the value of k in equation (3), we get

$$x' = \frac{x-vt}{\sqrt{(1-\frac{v^2}{c^2})}} \dots\dots\dots(8)$$

Now from equation (2),we get

$$t' = \frac{x'}{c} = \frac{x-vt}{c\sqrt{(1-\frac{v^2}{c^2})}}$$

$$t' = \frac{x/c-vt/c}{\sqrt{(1-\frac{v^2}{c^2})}} = \frac{t-vx/c^2}{\sqrt{(1-\frac{v^2}{c^2})}}$$

$$t' = \frac{t-vx/c^2}{\sqrt{(1-\frac{v^2}{c^2})}} \dots\dots\dots(9)$$

Hence, Lorentz transformation equations for space and time coordinates are as following:

$$x' = \frac{x-vt}{\sqrt{(1-\frac{v^2}{c^2})}} , y' = y, z' = z \text{ and } t' = \frac{t-vx/c^2}{\sqrt{(1-\frac{v^2}{c^2})}}$$

For low velocity i.e. in classical mechanics, $v \ll c$, so that $\frac{v}{c} \rightarrow 0$ and then Lorentz equations reduce to

$$x'=x-vt, y' = y, z' = z \text{ and } t'=t$$

This is Galilean transformation

Again the inverse transformation equations(from system L' to system L) can be obtained by replacing v by -v and writing x, y, z, t in place of x',y',z',t' and vice-versa, in the Lorentz transformation equations.

$$x = \frac{x'+vt'}{\sqrt{(1-\frac{v^2}{c^2})}} , y = y', z = z' \text{ and } t = \frac{t'+vx'/c^2}{\sqrt{(1-\frac{v^2}{c^2})}}$$

These are Lorentz inverse transformation equations.

Some facts on Lorentz transformation are as -

1. The world line of speed of light is the only such path which does not change when followed by a series of contraction and expansion.
2. The world line of speed of light is always at an angle 45° to the space time coordinate system.

Conclusion:

Greatly author work on the derivation of Lorentz transformation equation by the way of Einstein. A significance conclusion from Lorentz transformations is that nothing can move with velocity greater than the velocity of light.it means v should be less than c . If $v > c$, than

$\sqrt{(1 - \frac{v^2}{c^2})}$ would become imaginary making place and time coordinates also imaginary, which is impossible. Finally we can say the velocity of light c is the same in all the systems i.e. the speed of light c is an absolute constant and independent of frame of reference.

References:

1. Albert Einstein, Relativity: The Special and the General Theory, Appendix I, Simple Derivation of the Lorentz Transformation 1920, <http://www.Bartleby.com/173/a1.html>
2. Hans C. Ohanian, Special Relativity: A Modern Introduction,(Physics Curriculum & Instruction, 2001) pp.9-14
3. Kathleen A. Thompson, in Encyclopedia of Physical Science and Technology (Third Edition), 2003.

A SHORT REVIEW ON IONIC LIQUIDS STABILIZED COPPER AND COPPER OXIDE NANOPARTICLES AS CATALYSTS FOR ORGANIC CHEMICAL REACTIONS

Rajarajeswari A*¹ and Stella S²

¹Department of Chemistry, T.D.M.N.S. College,
Affiliated to Manonmaniam Sundaranar University,
Tirunelveli, 627113, Tamil Nadu, India

²Department of Chemistry and Research Centre,
Sarah Tucker College (Autonomous)
Affiliated to Manonmaniam Sundaranar University,
Tirunelveli, 627007, Tamil Nadu, India

*Corresponding author E-mail: rajarajeswaritdmns@gmail.com

Abstract:

Nanoparticles (NPs) play a significant role in various fields ranging from electronics to composite materials development. Among them, metal NPs have attracted much attention in recent decades due to their enhanced surface area, selectivity, tunable morphologies, and outstanding catalytic activity as compared to their respective bulk counterpart. Metal NPs stabilized by ionic liquids (ILs) are innovative and excellent catalysts for many organic conversions as the overall properties of the catalytic system can be designed by selecting an appropriate combination of the IL and metal NPs components. ILs are capable to restrict many of the negative impact of the conventional organic solvents during catalytic reactions. They have successfully been used in various catalytic areas affording high catalytic activity. The present review is aimed at exploring the applications of Copper (Cu) NPs combined with IL in few catalytic organic transformations. Organic transformations of interest include Michael type addition, Biginelli reaction, Decarboxylation C-C bond cleavage, Amination reaction and Heck reaction.

Introduction:

Room Temperature Ionic liquids (RTILs) or ILs are employed in the field of chemistry for decades. Several organic reactions utilize RTILs as a substitute for classical volatile organic solvent for maintaining the reaction medium. The key difference to conventional organic solvents is that ILs has no vapour pressure (Thomas and Marvey, 2016). Besides, they are able to

dissolve many compounds, and form two-phase systems with many solvents (Ratti, 2014). ILs has the advantage of reducing the organic solvent waste in different dimensions. ILs may replace the organic solvents which are dangerous, harmful and releases toxic component during the course of synthetic approach reaction (Clarke *et al.*, 2018). As solvents, ionic liquids have found applications in a numerous reactions. Most importantly, the physical and chemical properties of ILs can be tailored by altering their cation, anion and attached substituents (Hayes *et al.*, 2015). The application of ILs as catalytic phase in various organometallic reactions was extensively reviewed for so many years. Intensive research has also been made for catalytic applications of metal and its derivative in the form of nanoparticles immersed in ionic liquid media (Narayan *et al.*, 2019).

Cu NPs which has gained substantial attention in the last 20 years because of its unusual properties, leading to potential applications in many varied fields (Tamilvanan *et al.*, 2014). To exemplify, non-agglomerated, spherical, uniform Cu NPs finds use in lubrication, as nanofluids, medicine and catalyst etc. A number of methods namely microemulsion, reverse micelles, gamma irradiation, UV light irradiation, protecting electrolytic techniques by controlling electrode potential and the polyol process have been developed for the preparation of Cu NPs (Dewan *et al.*, 2012). A one phase system using alkanethiolate as a protecting monolayer has been described for the synthesis of Cu NPs. Besides, sonochemical methods and thermal decomposition methods have also been reported (Gawande *et al.*, 2016). However, the Cu NPs synthesized by these methods have their limitations as they have a limited size, are mono dispersed and can be degraded due to oxidation. Hence, there is a need to develop a methodology to synthesize Cu NPs with increased stability. It was postulated that ILs could be used in this respect to confer the stability to the nanoparticles. ILs have already emerged as a green alternative to the conventional and environmentally harmful volatile solvents (Narayan *et al.*, 2019). The Inherent properties of metal NPs along with ILs have been used extensively for use in sensors (Kachosangi *et al.*, 2009), material synthesis (Zhang *et al.*, 2010), separation and extraction (Germani *et al.*, 2007), asymmetric synthesis (Paczal and Kotschy, 2007), nuclear fuel cycle processing (Ha *et al.*, 2010), liquid thermal storage media and heat transfer fluids (Kamavaram and Reddy, 2008), lubricants (Liu *et al.*, 2006).

The main challenge in the development of catalytic NPs is to prepare nanomaterials that are highly active, selective, stable, robust, and inexpensive (Gawande *et al.*, 2016). One economical way of creating advanced Cu-based nanomaterials for catalysis is to immerse Cu NPs (e.g., Cu, CuO, or Cu₂O) in ionic liquid (Mohan *et al.*, 2013). Additionally, Cu's high

boiling point makes it compatible with high-temperature and pressure chemical reactions, including continuous flow reactions, microwave-assisted reactions, vapour phase reactions, and various organic transformations. This review includes organic transformations namely Michael addition between active methylene compound and α, β - unsaturated compounds, formation of dihydropyrimidinone from aldehydes, β -diketoester (ethylacetoacetate) and urea (or thiourea) (Bignelli reaction), amination of aryl halides, selective decarboxylative C–C bond cleavage, coupling of aryl halides with olefins (Heck reaction). Such unique properties, conducive for the development of reactive and selective catalytic systems, have made Cu and its compounds among the most valuable materials in the past, and will ensure that they remain significant in the future.

Role of Copper nanoparticles dispersed in ionic liquid for Michael addition:

A classical approach of performing Michael-type reaction in severe reaction conditions affects the efficiency of the reaction. This reaction involved either basic or acidic catalysts perturbing the desired outcome of the reaction. This limitation can be avoided by using an alternative catalyst namely $\text{Yb}(\text{OTf})_3$, InCl_3 , $\text{CeCl}_3 \cdot 7\text{H}_2\text{O}$, $\text{Bi}(\text{NO})_3$, $\text{Bi}(\text{OTf})_3$, $\text{Cu}(\text{OTf})_2$ and boric acid. Heterogeneous catalysts such as silica gels, Cu NPs, and $\text{CeCl}_3 \cdot 7\text{H}_2\text{O}/\text{NaI}$ system have experimented with Michael reaction. The role of ionic liquids substituting volatile organic solvents is the topic of research in the last decade. Cu NPs are highly efficient for the aza-Michael addition and thia-Michael addition reaction. This Cu NPs have turned up to be toxic in the presence of organic solvents.

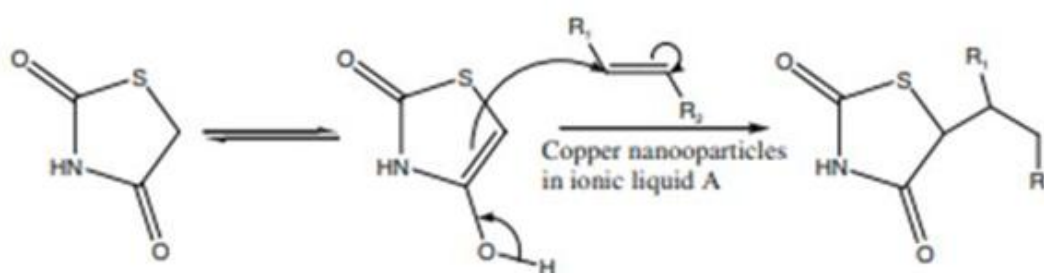

Figure 1. Michael addition reaction in presence of copper NPs in IL A

Singh *et al.* (2009), demonstrated to carry out the Michael addition reaction in a greener way. Cu NPs in an appropriate IL was employed as a catalyst for the reaction between active methylene compound and α, β -unsaturated compounds to give corresponding compounds in excellent yield along with shorter reaction times shown in Figure 1. A unique ionic liquid has been prepared by the combination of 1-H-tetrazole-5-acetic acid and acrylonitrile (Ionic liquid A). They conducted Michael addition between thiazolidine - 2, 4 - dione and different sets of

unsaturated compounds. All the reactions responded effectively well within 5–30 min. The yields of the desired Michael adducts were convincing. Branched acrylates such as iso-butyl and tert-butyl acrylate required somewhat longer reaction times than n-butyl acrylate. They also conducted the experiments for the addition reaction of thiazolidine–2, 4-dione, aniline and thiophenol individually with acrylonitrile for showing recycle probability of catalyst for five cycles and a gradual loss of activity of catalyst used in the experiment with cycle were examined.

The main objective of this research is to avoid the usage of toxic reagents, high temperatures and insist on the recyclability of the catalyst. It is noteworthy to conclude that the reaction can be accomplished in the presence of ionic liquid which makes the procedure simple, convenient and eco-friendly. Cu NPs were well characterized by TEM and XRD techniques. Structural characterizations of the products were elucidated done by ¹H-NMR, ¹³C-NMR, IR and mass analysis. The analysis of complete spectral and compositional data discovered the formation of Carba-Michael addition derivatives in 85-95% yield.

Role of Copper nanoparticles dispersed in ionic liquid for Biginelli Reaction:

The Biginelli reaction named after the Italian chemist Pietro Biginelli is a multiple-component chemical reaction that produces 3, 4-dihydropyrimidin-2(1H)-ones/thiones (DHPMs) from ethyl acetoacetate, an aryl aldehyde (such as benzaldehyde) and urea. It involves acid-catalyzed one-pot synthesis of DHPMs using easily-accessible starting materials, namely, aldehyde, active methylene compound and urea.

The Biginelli reaction provides direct access to large collections of molecules in combinatorial synthesis. The synthesised DHPMs have valuable biological activities. Dihydropyrimidones/thiones have displayed wide medicinal properties. These are calcium channel blockers, antihypertensive property, neuropeptide antagonists, antitumor, antibacterial, antiviral, anti-inflammatory, mitotic kinesin inhibitors, HIVgp-120-CD4 inhibitors and many more (Kaur *et al.*, 2017)

The original method offered several limitations such as low yield of products in the case of substituted and aliphatic aldehydes, harsh reaction conditions and long reaction time (Peng and Deng, 2001). Due to their important biological activities, several improved protocols have been reported. The numerous homogeneous catalysts, heterogeneous catalysts, ILs as a solvent or catalyst and immobilized IL over solid support are reported for this reaction.

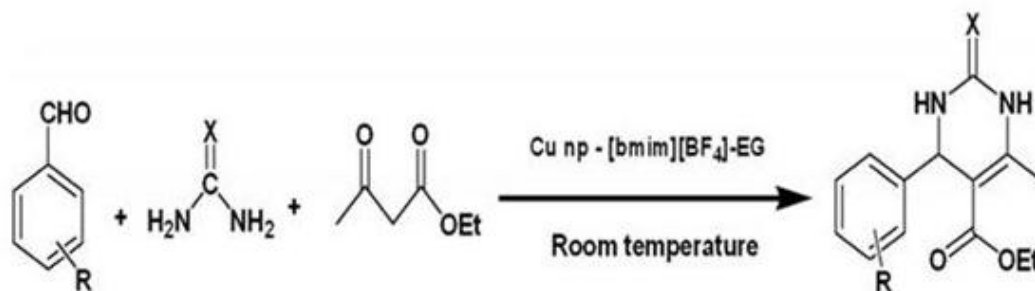

Figure 2. Cu NPs stabilised in [Bmim]BF₄, Ethylene glycol for Biginelli reaction

Dewan *et al.* (2012) reported a novel synthesis of Cu NPs from copper sulphate utilizing the charge-compensatory effect of ionic liquid [bmim]BF₄ and ethylene glycol. They showed that the Cu NPs mobilised in IL can be used as catalyst for Biginelli reaction at room temperature (Figure 2). The resultant product 3,4-dihydropyrimidinone from aldehydes, β -diketoester (ethylacetoacetate) and urea (or thiourea) gave 90% yield in 15 minutes. High yield and fast rate was found to be independent of the electronic density on the reactant aryl-aldehyde. This was probably because even the surface-active particles reacted at higher kinetics in the presence of IL as compared to classical methods.

This method has an easy work-up procedure and the NPs could be recycled with minimal loss of efficiency. Cu NPs dispersed in IL/ethylene glycol was used for the synthesis of 3,4-dihydropyrimidinones at room temperature with reduced reaction times and much higher yields. The ILs [bmim]BF₄ serves as an excellent media for dispersing Cu NPs, controlling their size and preventing their aerial oxidation; however agglomeration could not be avoided in the absence of ethylene glycol. On the other hand, while the reaction takes place effectively in the absence of hydrophilic ionic liquid [bmim]BF₄, the stability of the formed particles could not be extended for longer periods of time.

The proposed mechanism illustrates the postulated interaction of the acylimine intermediate with Cu NPs. It is interesting to note that the reaction progress rapidly to obtain high yields irrespective of whether electron-withdrawing or electron-donating side chains was attached to the reactant aryl aldehyde. The reaction of surface-active Cu NPs particles in the presence of IL is enhanced when compared to conventional methods was substantiated.

Role of Ligand-free copper(I) oxide nanoparticle-catalysed amination of aryl halides in ionic liquids:

An important organic synthesis is cross-coupling where two fragments are combined together with the help of a metal catalyst. Heck, Negishi and Suzuki, Nobel laureates in the field of Chemical science in 2010 for their novel work in cross-coupling catalysed by palladium.

Cross-coupling revolutionised catalytic organic chemistry for the past 3 decades. The most versatile and powerful bond-forming method in synthetic organic chemistry is cross-coupling which involves the coupling of two fragments in the presence of an appropriate catalyst. Coupling holds good for carbon-carbon, carbon-oxygen, and carbon-nitrogen bond formation.

Buchwald - Hartwig amination – This is the cross-coupling of an aryl (pseudo) halide and an amine.

Heck coupling - This illustrates the cross-coupling of an unsaturated halide with an alkene to form substituted alkenes.

Negishi coupling - This is the cross-coupling of an aryl (pseudo)halide and an organozinc nucleophile to form C-C bonds.

Sonogashira coupling- This Cross-coupling deals with the combination of an aryl (pseudo) halide with a terminal alkyne to give disubstituted acetylenes.

Stille coupling – This cross-coupling enumerates the coupling of an aryl (pseudo) halide and stannane. It is a functional reaction for carbon-carbon bond formation.

Suzuki - Miyaura coupling - This cross-coupling of an aryl (pseudo)halide and organoborane, is a versatile reaction for carbon-carbon bond formation.

Kebler *et al.* (2014), have attempted to present a simple and practicable methodology for a C–N coupling reaction using Copper (I) oxide (Cu_2O) catalysts combined with $n\text{-Bu}_4\text{POAc}$ IL (Figure 3). It is proved that an extensive range of amines and aryl halides can be coupled selectively in high yields. The reaction is carried out without the use of ligands or additives (bases) and also without caring the negative impact of air and water. Minimum dosage of catalyst as low as 5 mol%, depending upon the amount of substrate has been maintained. They examined the effect of the reaction parameters such as reaction time, temperature, catalyst loading along with effect of solvent, additives and inert atmosphere. Finally, they turned up with an adaptable and innovative methodology for the coupling of iodo- and bromobenzenes with a wide-ranging of amines and ammonia with a remarkable selectivity. It has to be pointed out that the synthesis of the Cu_2O nanoparticles proceeds directly in the used ionic liquid from cheap precursors like basic CuCO_3 with subsequent C–N coupling reactions. The as-synthesised nanoparticles are not separated or purified in an additional step but can be directly employed as catalysts for amination reactions. In contrast to many other homogeneous and heterogeneous catalyses, the coupling reaction in ionic liquid medium was found to happen without ligands, additional base, additives or an inert atmosphere and can even progress in the presence of water at temperatures below 80 °C.



Figure 3. C–N coupling reaction using Cu_2O catalysts combined with $n\text{-Bu}_4\text{POAc IL}$.

They carried experiments by this method for 30 systems. Aryl halides couple with ammonia or primary or secondary amines resulted in corresponding primary, secondary or tertiary amines in satisfactory to exceptional yields and selectivity. The nanoparticle catalyst was synthesised in $n\text{-Bu}_4\text{POAc}$ which was a polar ionic liquid and acted as a reaction medium, reductant and stabilising agent. As far as catalyst is concerned, it does not require any purification process and can be used as such in the amination reaction. The catalyst required is comparatively less as low as 5 mol%, and the whole reaction runs good without giving much attention for the prerequisite such as inert conditions nor any additional ligands, base or further additives

Role recyclable nanoscale copper(I) catalysts in ionic liquid media for selective decarboxylative C–C bond cleavage:

Functionalisation and defunctionalisation reactions play a vital role in the field of organic synthesis. Nanocatalysis has attracted much interest in this field of systematic synthetic research as a convenient and efficient tool. Currently, metal NPs and metal oxide NPs are employed for much organic application reactions such as hydrogenation, Fischer–Tropsch reactions and cross-coupling reactions. Decarboxylative carbon-carbon cross-coupling reactions have emerged as an important tool in synthetic chemistry for decarboxylation reactions. It is initiated by a decarboxylative step of a carboxylate salt, which represents an economic approach for expensive organometallic reagents.

Due to the leaching effects which decrease the yields of the reaction, metal and metal oxide NPs are introduced in the reaction medium along with nitrogen or phosphor-containing ligands, surfactants, or polymers. An effective way to defunctionalise an electron-deficient aromatic system carrying carboxylic acid is the photodecarboxylation reaction. Here defunctionalize takes place in the presence of a Cu(I) catalyst. While highly activated carboxylic acids (e.g. perfluorinated benzoic acids) readily decarboxylate without any catalyst, the removal

of the carboxylate groups from simple aromatic acids is much more complicated and often requires harsh reaction conditions.

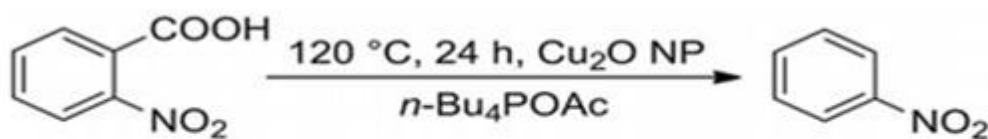

Figure 4. Protodecarboxylation of 2-nitrobenzoic acid in present of Cu₂O-NPs stabilized Phosphonium IL

Kebler *et al.* (2013) reported that nanoscale copper (I) oxide (Cu₂O-NPs) embedded in phosphonium ionic liquids is an active and recyclable catalyst for ligand- and additive-free protodecarboxylation of 2-nitrobenzoic acid (Figure 4). and its derivatives. The reactions were carried out with low catalyst loadings along with appreciable quantitative yield in ten consecutive recycling experiments. Photodecarboxylation reaction overcomes one important limitation namely selectivity of decarboxylation reactions towards different benzoic acid derivatives. Protodecarboxylation reactions can be easily conducted with Benzoic acids containing an electron-deficient aromatic ring system irrespective of the substituents in the ring. This reaction was convincingly carried out in the presence of a copper catalyst in ionic liquid. This nano catalytic approach is the first that can selectively decarboxylate 2-nitrobenzoic acid in the presence of other benzoic acids with comparable electron poor aromatic rings with considerable yields.

Role of Cu Nanoparticles in ionic liquid for Heck reaction:

The Heck reaction which is also called the Mizoroki–Heck reaction is the chemical synthetic approach for preparing substituted alkene from unsaturated halide with an alkene in the presence of a base and a palladium catalyst. Here, palladium can also be introduced in the reaction medium as NPs.

Actually, Heck reaction is classified under the cross-coupling reaction between alkenes and aryl or vinyl halides to synthesise the desired substituted alkenes. The significance of the reaction is carbon–carbon bond formation for synthetic applications.

An economic approach has been designed to eliminate the limitation due to the recovery as well as recycling of the expensive Pd catalyst which is mandatory. An alternative method is the usage of cheaper metals as catalyst namely copper. To substantiate the above concept, Calo

et al. (2005) experimented the catalytic performance of copper nanocolloids in presence of tetrabutylammonium bromide (TBAB) as solvent and tetrabutylammonium acetate (TBAA) as base for the Heck reaction (Figure 5). Recycling ability of the catalyst has also been enhanced economically by addition of Cu NPs in IL. Copper nanocolloid, derived from the reaction of iodobenzene with copper bronze, does catalyse the reactions of aryl iodides and activated bromides in IL. The catalytic system was recycled 20 times which has resulted with an average total Turnover number (TON) of 490. The TON value has made this metal nanocolloid extremely stable in TBAB IL and can be stored for months without a loss of activity.

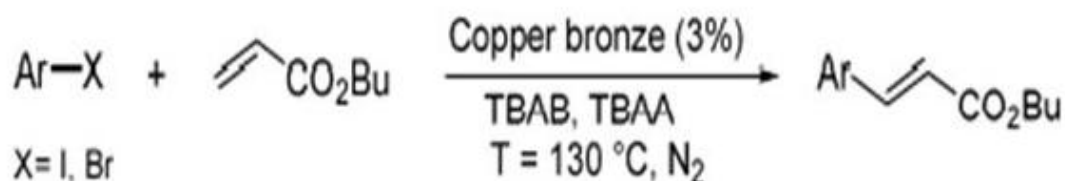

Figure 5. Copper nanocolloids in presence of TBAB, TBAA for the Heck reaction.

The reason of positive impact of tetrabutylammonium salts on the reaction rates and catalyst stabilization emerges may be due to the formation of Cu NPs surrounded by appreciable tetra alkyl ammonium salt. This factor creates Coulombic barrier for collision, hinder the formation of clusters growing further into metal particles. Thus, they have successfully attempted Cu NPs in ILs do catalyse the Heck reaction, and act as a cost effective, greener approach to substitute noble metal catalysts.

Conclusion:

This review has highlighted the protocol and its impact for the usage of Cu NPs and Cu₂O NPs in ILs for the different synthetic organic catalysis. These procedures make it possible to control the properties of the nanosystems for enhancing the rate and yield of the reaction. The above experimental approach avoids the use of expensive reagents, high temperatures and serves as an efficient method to allow easy recyclability of the catalyst. It is remarkable that the reactions can be performed in ionic liquid which makes the procedure quite simple, more convenient and greener approach. In summary, these procedures show benefits in versatility, selectivity, affectivity and preparative demand which clearly distinguish it from the earlier reports.

Reference:

1. Thomas, P.A. and Marvey, B.B., 2016. Room temperature ionic liquids as green solvent alternatives in the metathesis of oleochemical feedstocks. *Molecules*, 21(2), pp.184.
2. Ratti, R., 2014. Ionic liquids: synthesis and applications in catalysis. *Adv. Chem*, 2014(3), pp.1-16.
3. Clarke, C.J., Tu, W.C., Levers, O., Brohl, A. and Hallett, J.P., 2018. Green and sustainable solvents in chemical processes. *Chemical reviews*, 118(2), pp.747-800.
4. Hayes, R., Warr, G.G. and Atkin, R., 2015. Structure and nanostructure in ionic liquids. *Chemical reviews*, 115(13), pp.6357-6426.
5. Narayan, N., Meiyazhagan, A. and Vajtai, R., 2019. Metal nanoparticles as green catalysts. *Materials*, 12(21), pp.3602.
6. Tamilvanan, A., Balamurugan, K., Ponappa, K. and Kumar, B.M., 2014. Copper nanoparticles: synthetic strategies, properties and multifunctional application. *International Journal of Nanoscience*, 13(02), pp.1430001.
7. Dewan, M., Kumar, A., Saxena, A., De, A. and Mozumdar, S., 2012. Biginelli reaction catalyzed by copper nanoparticles. *Plos one*, 7(8), pp. 43078.
8. Gawande, M.B., Goswami, A., Felpin, F.X., Asefa, T., Huang, X., Silva, R., Zou, X., Zboril, R. and Varma, R.S., 2016. Cu and Cu-based nanoparticles: synthesis and applications in catalysis. *Chemical reviews*, 116(6), pp.3722-3811.
9. Narayan, N., Meiyazhagan, A. and Vajtai, R., 2019. Metal nanoparticles as green catalysts. *Materials*, 12(21), pp.3602.
10. Kachoosangi, R.T., Musameh, M.M., Abu-Yousef, I., Yousef, J.M., Kanan, S.M., Xiao, L., Davies, S.G., Russell, A. and Compton, R.G., 2009. Carbon nanotube– ionic liquid composite sensors and biosensors. *Analytical chemistry*, 81(1), pp.435-442.
11. Zhang J, Wang J, Zhou S, Duan K, Feng B, *et al.* (2010) Ionic liquid-controlled synthesis of ZnO microspheres *J. Mater. Chem.* 20, pp.9798–9804.
12. Germani R, Mancini MV, Savelli G, Spreti N (2007) Mercury extraction by ionic liquids: temperature and alkyl chain length effect. *Tetrahedron Letters* 48: pp. 1767–1769.
13. Paczal A, Kotschy A, 2007 Asymmetric synthesis in Ionic Liquids. *Monatshheft für Chemie* 138, pp.1115–1123.
14. Ha SH, Menchavez RN, Koo YM (2010) Reprocessing of spent nuclear waste using ionic liquids. *Korean J Chem Eng* 27: 1360–1365.

15. Kamavaram V, Reddy RG (2008) Thermal stabilities of di-alkylimidazolium chloride ionic liquids. *International Journal of Thermal Sciences* 47: 773–777.
16. Liu X, Zhou F, Liang Y, Liu W (2006) Benzotriazole As The Additive For Ionic Liquid Lubricant: One Pathway Towards Actual Application of Ionic Liquid, *Tribology Letters* 23: 191–196.
17. Mohan, B., Woo, H., Jang, S., Lee, S., Park, S. and Park, K.H., 2013. Synthesis of monodisperse Cu nanoparticles in Ionic Liquids: A synthetic and catalytic approach of in situ nanoparticles. *Solid state sciences*, 22, pp.16-20.
18. Singh, P., Kumari, K., Katyal, A., Kalra, R. and Chandra, R., 2009. Copper nanoparticles in ionic liquid: an easy and efficient catalyst for selective Carba-Michael addition reaction. *Catalysis letters*, 127(1), pp.119-125.
19. Keßler, M.T., Robke, S., Sahler, S. and Prechtel, M.H., 2014. Ligand-free copper (I) oxide nanoparticle-catalysed amination of aryl halides in ionic liquids. *Catalysis Science & Technology*, 4(1), pp.102-108.
20. Keßler, M.T., Gedig, C., Sahler, S., Wand, P., Robke, S. and Prechtel, M.H., 2013. Recyclable nanoscale copper (I) catalysts in ionic liquid media for selective decarboxylative C–C bond cleavage. *Catalysis Science & Technology*, 3(4), pp.992-1001.
21. Calo, V., Nacci, A., Monopoli, A., Ieva, E. and Cioffi, N., 2005. Copper bronze catalyzed heck reaction in ionic liquids. *Organic letters*, 7(4), pp.617-620.
22. Kaur, R., Chaudhary, S., Kumar, K., Gupta, M.K. and Rawal, R.K., 2017. Recent synthetic and medicinal perspectives of dihydropyrimidinones: A review. *European journal of medicinal chemistry*, 132, pp.108-134.
23. Peng, J. and Deng, Y., 2001. Ionic liquids catalyzed Biginelli reaction under solvent-free conditions. *Tetrahedron Letters*, 42(34), pp.5917-5919.

IMPORTANCE AND APPLICATIONS OF NANOPARTICLES IN DAILY LIFE

Jyoti Agashe

Department of Chemistry,

HPT Arts and RYK Science College,

Nashik, Maharashtra, India

Corresponding author E-mail: jyotiagashe@gmail.com

Introduction of Nanoparticles:

A nanoparticle is a very small unit with dimensions measured in nanometres (nm; 1 nm = 10^9 metre). Nanoparticles can be found in nature and are also produced as a result of human activity. Nanoparticles have unique material properties due to their submicroscopic size, and they may find practical uses in a range of fields, including medicine, engineering, catalysis, and environmental remediation.

According to their size, shape, and material characteristics, nanoparticles can be categorised into a variety of kinds. Dendrimers, liposomes, and polymeric nanoparticles go into the organic category, whereas fullerenes, quantum dots, and gold nanoparticles fall into the inorganic category. Nanoparticles are classified as carbon-based, ceramic, semiconducting, or polymeric in other categories. Nanoparticles can also be classified as hard (e.g., titania [titanium dioxide], silica [silica dioxide] particles, and fullerenes) or soft (e.g., silica [silica dioxide] particles, and fullerenes) (e.g., liposomes, vesicles, and nanodroplets). The classification of nanoparticles is often determined by their intended use, such as diagnosis or therapy vs fundamental research, or by the method by which they were created. Nanoparticles have three distinct physical properties, all of which are interconnected: (1) They are very mobile in the free state (a 10-nm-diameter nanosphere of silica in water has a sedimentation rate of 0.01 mm/day under gravity in the absence of any other extra impact); (2) they have large specific surface areas (a normal teaspoon, or roughly 6 ml, of 10-nm-diameter silica nanospheres has more surface area than a dozen doubles-sized tennis courts; 20% of all the atoms in each nanosphere are situated at the surface); and (3) they may show quantum phenomena. As a result, nanoparticles come in a wide variety of compositions, which vary depending on the application or product.

Benefits and Applications:

Information technology, homeland security, medicine, transportation, energy, food safety, and environmental science are just a few of the technology and industry sectors that nanotechnology is helping to enhance, if not transform. The list of benefits and applications of nanotechnology described below is just a small sample of the ever-growing list.

Medicine

Nanotechnology is already expanding the range of medical instruments, information, and treatments available to doctors. Nanomedicine, or the use of nanotechnology in medicine, uses the natural scale of biological events to provide precise disease prevention, diagnosis, and treatment solutions. Here are a few examples of recent developments in this field:

- Gold nanoparticles have been adapted as probes for the detection of targeted nucleic acid sequences in commercial applications, and gold nanoparticles are also being clinically explored as potential cancer and other illness treatments.

Nanotechnology is opening the path for earlier diagnosis, more customised treatment options, and higher therapeutic success rates by enabling improved imaging and diagnostic tools.

- Atherosclerosis, or plaque accumulation in arteries, is being investigated using nanotechnology for both diagnosis and therapy. Researchers used one approach to make a nanoparticle that mimicked the body's "good" cholesterol, known as HDL (high-density lipoprotein), which aids in plaque reduction.

The development of revolutionary gene sequencing technologies that enable single-molecule detection at cheap cost and high speed with little sample preparation and instrumentation could be enabled by the design and manufacturing of enhanced solid-state nanopore materials.

- Nanotechnology researchers are working on a variety of therapies in which a nanoparticle can encapsulate or otherwise assist in the delivery of medication directly to cancer cells while minimising the danger of harming healthy tissue. This has the potential to transform how doctors treat cancer and drastically minimise chemotherapy's side effects.

Nanoparticles have become important players in modern medicine in recent years. They're being studied for a variety of clinical uses, including medication and gene delivery to malignancies, as well as contrast agents in imaging. Drugs are delivered to tumours via polymeric micelle nanoparticles, while carbon nanoparticles termed nanodiamonds are being explored for use in various medical applications. Protein molecules, for example, can be linked to nanodiamonds to promote bone formation around joint or dental implants.

Chemotherapy medications connected to nanodiamonds are being studied for brain tumour treatment, and some researchers are exploring the possibility of using them to treat leukaemia as well.

In photodynamic cancer therapy, a particular dye is utilised to produce atomic oxygen, which is cytotoxic. When compared to healthy tissue, cancer cells absorb the majority of this dye. As a result, only the cancer cells are eliminated, after which they are subjected to laser radiation. The leftover dye molecules spread to the eyes and skin, rendering the patient extremely sensitive to daylight exposure.

Manufacturing and Materials:

Many firms are utilising nanotechnology to build goods with enhanced capabilities or lower production costs. Purdue University researchers used a bench-top device to demonstrate a technology called laser shock imprinting, which makes nanoscale metallic forms with appealing optical and mechanical qualities. This is a low-cost system that can create the forms in big quantities. This shock-induced forming process has the benefit of producing high-fidelity structures with strongly defined vertical features and corners.

Northwestern University researchers developed a low-cost, high-resolution nanofabrication tool that uses beam-pen lithography arrays to create nanoscale structures in a separate study. In a single experiment, users can process substrates coated with photosensitive materials known as resists and generate shapes that span the micro, macro, and nanoscales.

The core of nanoscale science and engineering is materials fabrication and innovation. Nanotechnology allows you to change the key structures of materials at the nanoscale to get the attributes you want. Materials can be made lighter, stronger, more durable, sieve-like, reactive, and better electrical conductors using nanotechnology.

Additives in polymer composite materials for tennis rackets, baseball bats, automobile bumpers, motorcycle helmets, power tool housings, and luggage are among the over 800 commercial products that rely on nanoscale processes and materials to make them strong, lightweight, resilient, and long-lasting. Similarly, using nanoscale compounds for fabric surface treatments make them stain, wrinkle, and bacterial growth resistant.

Everyday Materials and Processes:

Materials can be made stronger, lighter, more durable, more reactive, sieve-like, or better electrical conductors using nanotechnology, among other characteristics. Many commercial

items that rely on nanoscale materials and technologies are currently on the market and in daily use:

- Clear nanoscale films applied to eyeglasses, computer and camera displays, windows, and other surfaces can make them water and residue repellent, antireflective, self-cleaning, UV or infrared light resistant, antifog, antimicrobial, scratch-resistant, or electrically conductive.

Nanoscale materials are enabling washable, long-lasting "smart fabrics" with flexible nanoscale sensors and electronics for health monitoring, solar energy capture, and energy harvesting through movement.

- Cars, trucks, aeroplanes, boats, and spacecraft that are lighter might save a lot of fuel. Baseball bats, tennis rackets, bicycles, motorcycle helmets, vehicle parts, luggage, and power tool housings all utilise nanoscale additions in polymer composite materials to make them lightweight, rigid, robust, and resilient. Carbon nanotube sheets are now being manufactured for use in future air vehicles.

For example- They're perfect for applications like electromagnetic shielding and thermal control because of their light weight and conductivity.

Nanostructured ceramic coatings for machine parts are far more durable than traditional wear-resistant coatings. Nanotechnology-enabled lubricants and motor oils also reduce wear and tear, allowing moving parts in everything from power tools to industrial gear to last longer.

- Catalysis with nanoparticles is becoming more popular as a way to speed up chemical reactions. This lowers the amount of catalytic materials required to achieve the desired outcomes, saving money and lowering pollution. Petroleum refinery and automotive catalytic converters are two major applications.

Degreasers and stain removers, environmental sensors, air purifiers, and filters, antibacterial cleansers, and specialty paints and sealing solutions, such as self-cleaning home paints that resist dirt and stains, are all made with nano-engineered materials.

Energy Applications:

Nanotechnology is boosting alternative energy approaches and finding applications in existing energy sources to help satisfy the world's growing energy demands. Many scientists are working on developing clean, economical, and renewable energy sources, as well as measures to cut energy usage and reduce environmental toxicity:

- Better catalysis enabled by nanotechnology is increasing the efficiency of fuel synthesis from raw petroleum materials. It also allows for lower fuel use in vehicles and power plants due to improved combustion efficiency and reduced friction.

The use of nanotechnology-enabled gas lift valves in offshore operations, or the use of nanoparticles to detect small down-well oil pipeline fractures, are examples of how nanotechnology is being used in oil and gas extraction.

- To extract carbon dioxide from power plant exhaust, researchers are looking into carbon nanotube "scrubbers" and membranes.
- Researchers are working on carbon nanotube-based wires that will have far lower resistance than the high-tension wires currently used in the electric grid, resulting in decreased transmission power loss.

Nanotechnology can be used into solar panels to improve the efficiency with which sunlight is converted to energy, resulting in more affordable solar power in the future. Because nanostructured solar cells may be manufactured using print-like methods and are constructed in flexible rolls rather than discrete panels, they may be less expensive to produce and instal. According to new research, future solar converters may even be "paintable."

- Nanotechnology is already being used to build a variety of new types of batteries that are faster to charge, more efficient, lighter in weight, have a higher power density, and last longer.

Environmental Remediation:

There are various ways that nanotechnology can help identify and clean up environmental toxins, in addition to the ways that it can help enhance energy efficiency (see the section above).

- Engineers have developed a thin film membrane with nanopores for energy-efficient desalination, which might help satisfy the need for inexpensive, clean drinking water through rapid, low-cost detection and treatment of pollutants in water. This MoS₂ membrane filtered two to five times more water than contemporary conventional filters.

Nanoparticles are being created to remove industrial water contaminants from ground water by chemical processes that render the pollutants harmless. This method would be less expensive than systems that require the water to be pumped out of the ground for treatment.

- For cleanup purposes, researchers devised a nanofabric "paper towel" made from tiny wires of potassium manganese oxide that can absorb 20 times its weight in oil. Researchers have also employed magnets to mechanically remove oil from spills with magnetic water-repellent nanoparticles.

Many aircraft cabin and other types of air filters use nanotechnology to enable "mechanical filtration," in which the fibre material forms nanoscale pores that catch particles larger than the pores' size. The filters may additionally have charcoal layers to absorb odours.

Polymers:

Carbon and silica nanoparticles have been employed as fillers in rubber to improve the mechanical qualities of tyres, and similar particles, as well as nanoclays, have been put into polymers to improve their strength and impact resistance. The creation of “all-natural” nanocomposite polymers was spurred by the increased usage of non-petroleum-based polymers obtained from natural sources in the early twenty-first century.

A biopolymer made from alginate (a carbohydrate found in the cell wall of brown algae), cellulose, or starch is utilised in combination with natural nanoclay or a filler obtained from crustacean shells in such products. The materials are biodegradable and leave no possibly hazardous or non-natural leftovers behind.

Food packaging:

Food packaging is increasingly using nanoparticles to manage the ambient environment surrounding food, keeping it fresh and free of microbial infection. Clay nanoflakes and claylike particles are used in these composites, which limit moisture infiltration and minimise gas transfer over the packaging sheet. Nanoparticles with antibacterial properties (for example, nanocopper or nanosilver) can likewise be incorporated into such packaging. Antimicrobial nanoparticles have also been put into paints and varnishes, making them especially beneficial for surfaces in hospitals and other medical institutions, as well as food preparation areas.

Flame retardants:

Nanoparticles were investigated for their potential to replace flammable organic halogens and phosphorus-based additives in plastics and textiles. According to studies, products using nanoclays and hydroxide nanoparticles emit fewer toxic gases in the event of a serious fire than products having certain other types of additives.

Batteries and supercapacitors:

The ability to construct nanocomposite materials with large interior surface areas for storing electrical charge in the form of tiny ions or electrons has made them particularly useful for batteries and supercapacitors. Nanocomposite materials have been developed for a variety of electrode-related applications. Carbon nanotube-based composite materials and layered-type materials, such as graphene, were also widely investigated, with commercial products starting appearing in the early 2000s

Nanoceramics:

The transformation of brittle, crack-prone ceramics into harder, more robust materials has been a long-term goal in materials science. Researchers had accomplished this goal by adding an effective combination of nanoparticles into ceramic materials by the early twenty-first century. All-ceramic or polymer-ceramic blends, which integrated the distinctive functional (e.g., electrical, magnetic, or mechanical) qualities of a nanocomposite material with the properties of ceramics materials, were among the other innovative ceramics materials under study.

References:

1. Aksu Z, Proc. Biochem., 40, 997-1026 (2005).
2. Allen M, Bulte J W, Liepold L, Basu G, Zywicke H A, Magn.Reson. Med., 54, 807-812 (2005)
3. Astuti Y, Palomares E, Haque S A, Durrant J R, J Am. Chem Soc., 127, 15120 (2005).
4. Gref R, Minamitake Y, Perachhia M T, Trubetskoy V, Langer R, Science, 263, 1600-1603 (1994).
5. De M, Ghosh P S, Rotello V M, Adv. Mater., 20, 4225-5241, 2008.
6. Neuman D, Ostrowski A D, Absalonson R O, Strouse G F, Ford P C, J. Am. Chem. Soc., 129, 4146-4147 (2007).
7. Derfus A M, Von Maltzann G, Harris T J, Duza T, Adv. Mater., 19, 3932-3936 (2007).

Advanced Research in Material and Chemical Science Volume I

ISBN: 978-81-951982-9-0

About Editors



Dr. Nana N. Shejwal is currently working as an Assistant Professor in the Department of Engineering Science, All India Shri Shivaji Memorial Society's, College of Engineering, Pune (MS) India. He has 25 years of experience in teaching, research, innovation and industry. He has more than 30 research publications from SCI / SCOPUS / WEB of science indexed journals cited for number of times. His h-index is 4 and i10-index is 3. He has 02 books and 05 book chapters in National/International edited books to his credits. He has undertaken a research projects at National level funded by BCUD, Savitribai Phule Pune University, Pune and other funding agencies. Dr. Shejwal has delivered invited talk at various International/National/State Conference/Workshops/Refresher and Orientation program. He has received many awards. He has worked as organizing coordinator, conveyer, and chairman of various programs. He has shouldered several other administrative responsibilities. Dr. Shejwal implementing socio-techno project in the area of Health, Education, Employability, women Empowerment, water conservation and energy for the village development.



Dr. Simanchal Das is currently working as an Assistant Professor and Head in the Department of Chemistry, Roland Institute of Technology under BPUT University, Odisha. He has 10 years of research and 22 years of teaching experiences in the field of chemistry at different levels. Dr. Das obtained his Ph.D. in Supramolecular Chemistry from Berhampur University, Berhampur, Odisha. In his credit 23 Publications in international, national journals and publishers. He has been presented eight papers in national and international conferences. Dr. Das has organized 02 conference/workshops. He has participated more than fifty national, International seminars, conferences, Workshops and Faculty Development Programme. His area of interest includes supramolecular chemistry, environmental science and material science. Dr. Das received two awards for research excellence and best educator. Dr. Das is a reviewer/editor of different national and international journals. He has life time member of several professional bodies like Indian Society for Technical Education (ISTE), Indian Science Congress Association (ISCA), Odisha Chemical Society (OCS), Odisha Environmental Society (OES), Institute of Scholars (InSc) etc.



Dr. Pralhad Rege is working as Assistant Professor in the Department of Chemistry, St. Xavier's College Mumbai. He has completed Ph.D. in Analytical Chemistry. He also holds PGDHRM from Symbiosis, Pune and PG Diploma in Clinico-Regulatory and Patents from Ruia College. His teaching experience is 14 years and research experience is 12 years. His area of research interest is Analytical chemistry, Pharmaceutical chemistry, synthetic chemistry and Herbal science. Dr. Rege published 22 research papers in various national and international, actively participated in more than 70 conferences / workshops/ Seminars/ online FDP's. He has presented 15 research papers in the form of Oral / poster presentations. Dr. Rege is Mumbai University recognized guide for M. Sc. by research and Ph.D. Currently two students for M. Sc. by research and three students for Ph.D. are working under his guidance. He is working as Advisory and Editorial member of various National and International journals. He also serves his duties as a visiting faculty in various UG and PG institutes. He received the Best Researcher Award by VDG00D Professional Association Chennai, Tamil Nadu, India.



Dr. Venkatesh Gopula is presently working as Assistant Professor in Department of Chemistry at Anandibai Raorane Arts, Commerce and Science College, Vaibhawwadi, Dist. Sindhudurg (Affiliated to University of Mumbai). He has completed M. Sc. in Chemistry, Ph. D. from S. R. T. M. University, Nanded and qualified NET exam as well. The research work carried out during his Ph. D. was "Organocatalysis for the development of an efficient and green organic Synthesis". He has published research work in reputed journals like Tetrahedron letters and RSC Advances. His area of research is synthetic organic chemistry and organocatalysis. Dr. Gopula has 4 years of UG and 2 years of PG teaching experience. He is recipient of Rajiv Gandhi National Fellowship for Ph. D. work. Apart from teaching responsibility, he contributed in various administrative, curricular and co-curricular activities organized by institute.

